

VALVES

● VALVES	B1
● VALVES ISLANDS AND FIELDBUS	B2

VALVES SUMMARY



- **MINIVALVES SERIES VME, MECHANICALLY HAND OPERATED**
ADDITION TO THE CATALOGUE

B1.4



- **VALVES SERIES 70, HAND OPERATED**
ADDITION TO THE CATALOGUE

B1.6



- **VALVES SERIES 70, MECHANICALLY OPERATED, 1/8"**
ADDITION TO THE CATALOGUE

B1.9



- **VALVES SERIES 70 PNEUMATIC**
ADDITION TO THE CATALOGUE

B1.12

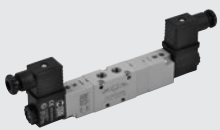

- **VALVES SERIES 70, SOLENOID/PNEUMATIC**
ADDITION TO THE CATALOGUE

B1.13

- **REPOSITIONING FOR VALVES SERIES 70**

B1.16



- **PILOT WITH THROUGH BASE**

B1.17



- **MACH 16 VALVES FOR SECONDARY**

B1.18

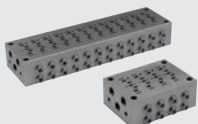

- **MULTIPLE BASES FOR MACH 18 VALVES**

B1.19



- **VALVES ISO 5599/1, PNEUMATIC SERIES IPV**
ADDITION TO THE CATALOGUE

B1.20



- **VALVES ISO 5599/1, SOLENOID/PNEUMATIC, SERIES ISV**
ADDITION TO THE CATALOGUE

B1.21

MINIVALVES SERIES VME, MECHANICALLY HAND OPERATED ADDITION TO THE CATALOGUE

- Minivalves with 2/2 or 3/2 NO NC poppet
- Installation in any position
- Push-in fittings for pipe Ø 4, Ø 6 mm and M5 on the valve body
- Low actuation force
- Rapid, accurate signal
- Mechanical actuation
- The 2 places adapter allows manual actuation of 1 or 2 VME valves with manual Ø 22 panel actuators. Thus it is possible to obtain 3/2, 5/2, 5/3 open centre and 5/3 pressure centre pneumatic functions.
- On request, it is possible to place a NC-NO electric switch next to a VME valve for mixed solenoid/pneumatic signals.



TECHNICAL DATA	
Valve fitting port	Push-in fitting for pipe Ø 4 or Ø 6 and M5 (axial or side)
Fluid	Filtered air without lubrication; lubrication, if used, must be continuous
Type	With poppet
Versions	Mechanical and manual
Operators:	With Plunger – Plunger for wall-mounting – Roller lever – Unidirectional roller lever
• mechanical	Depending on the type of actuation panel selected
• manual	
Operating pressure	bar
Operating temperature range	°C
Nominal diameter	mm
Conductance C	Nl/min · bar
Critical ratio b	bar/bar
Flow rate at 6 bar ΔP 0.5 bar	Nl/min
Flow rate at 6 bar ΔP 1 bar	Nl/min
Actuation force – Plunger at 6 bar	N
Recommended lubricant	ISO and UNI FD22
Installation	In any position
Compatibility with oils	Look at the technical documentation at page 6-7 of general catalogue

COMPONENTS

- ① VALVE BODY: Aluminium
- ② BUTTON: chemically nickel-plated brass
- ③ DISTANCE PLATES: Brass
- ④ GASKETS: NBR
- ⑤ PUSH-IN FITTING CARTRIDGES: stainless steel, brass and plastic
- ⑥ SPRINGS: stainless steel

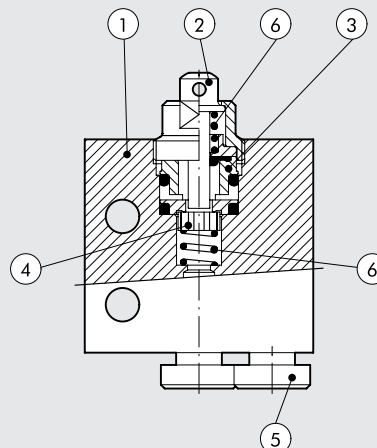

ROLLER LEVER 2/2 NC Ø 4 - SIDE FITTINGS

Code	Description	Weight [g]
8286919	VME2-0S NC Ø4	42

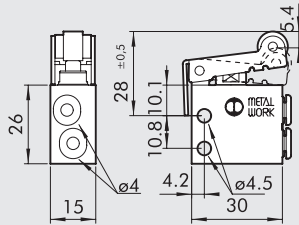

PLUNGER 3/2 NO Ø 6 - AXIAL FITTINGS

Code	Description	Weight [g]
W3501000130	VME1-30 NO Ø6	51

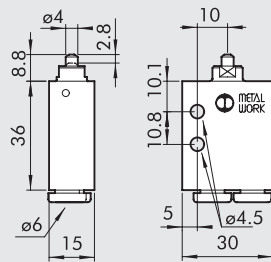

PLUNGER 3/2 NC Ø 6 - AXIAL FITTINGS

Code	Description	Weight [g]
W3501000131	VME1-31 NC Ø6	51

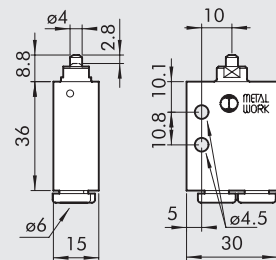

VALVES SERIES 70, HAND OPERATED ADDITION TO THE CATALOGUE

TECHNICAL DATA		1/8"	1/4"	1/2"
Operating pressure range:				
• version with direct control	bar	Vacuum ÷ 10		
• Pilot-assisted version	bar	from 2.5 to 10		
Operating temperature range				
	°C	from -10 to +60		
Nominal diameter				
	mm	5	7.5	15
Conductance C				
	Nl/min · bar	121.43	264.26	971.43
Critical ratio b				
	bar/bar	0.32	0.27	0.43
Flow rate at 6 bar ΔP 0.5 bar				
	Nl/min	400	750	3200
Flow rate at 6 bar ΔP 1 bar				
	Nl/min	550	1100	4600



SYNOPTIC, SIZES AND VERSION

M A V	2	3	PP	S	NC
FAMILY	DIMENSIONS	FUNCTION	OPERATION 14	REPEATED OPERATION (12)	FURTHER DETAILS
MAV manual valves	2 1/8"	3 3/2	PP drawer	A pneumatic/ mechanical spring*	NC normally closed
	3 1/4"	5 5/2	VL axial lever	S mechanical spring	NO normally open
	4 1/2"	6 5/3	LE 90° lever	B bistable	OO no indication
		8 2 x 3/2	BRE arranged for manual panel actuators	D differential	CC closed centres
			SP special	O stable for 5/3	OC open centres
				P pneumatic	PC pressure centres
					SP special

*on demand

VALVES SERIES 70, HAND OPERATED, 1/8"

FRONT LEVER 3/2, 1/8" MONOSTABLE

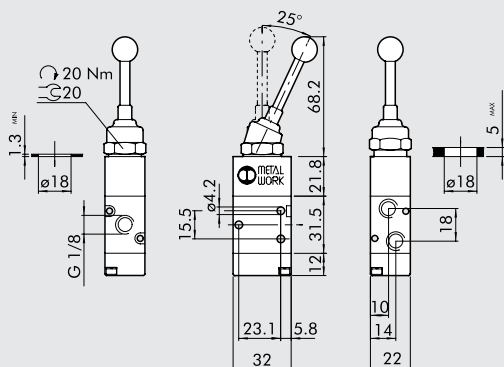

Symbol	Code	Abbrev.	Weight [g]
	8800801	MAV 23 VLS NC	130

FRONT LEVER 5/2, 1/8" MONOSTABLE

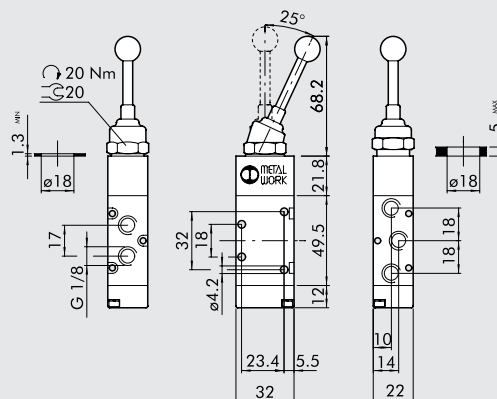

Symbol	Code	Abbrev.	Weight [g]
	8826334	MAV 25 VLS OO	156

90° ANGULAR LEVER 5/3, 1/8" WITH 2 STABLE POSITIONS

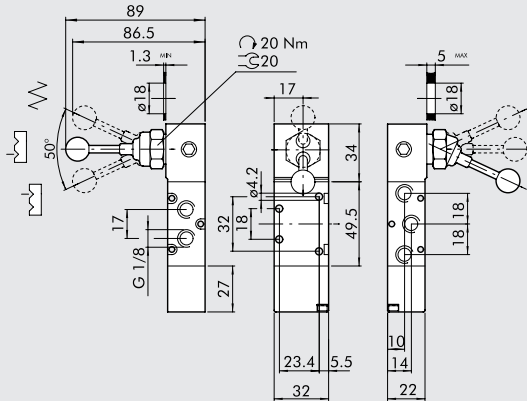

Symbol	Code	Abbrev.	Weight [g]
	8829106	MAV 26 SPB CC	242
	8294569	MAV 26 SPB OC	242

RED DRAWER 3/2, 1/8"

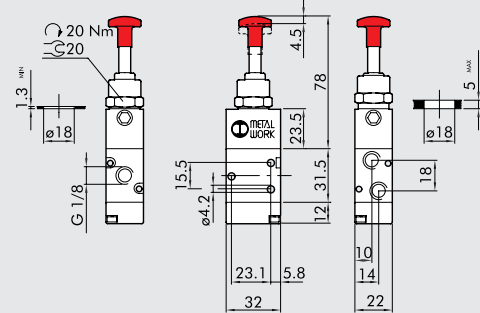

Symbol	Code	Abbrev.	Weight [g]
	7010001301	MAV 23 PPB OO	134
	7010001201	MAV 23 PPS NC	134

RED DRAWER 5/2, 1/8"

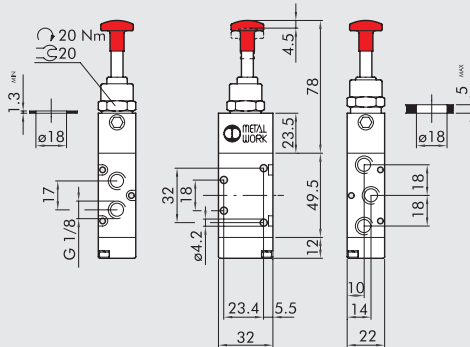

Symbol	Code	Abbrev.	Weight [g]
	7010001601	MAV 25 PPB OO	160
	7010001501	MAV 25 PPS OO	160

DRAWER 3/2, 1/8" PNEUMATIC RETURN

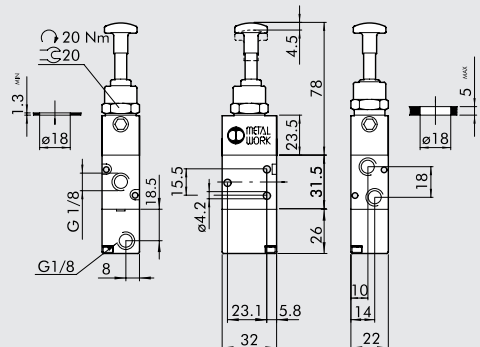

Symbol	Code	Abbrev.	Weight [g]
	8826503	MAV 23 PPP NC	148

DRAWER 5/2, 1/8" PNEUMATIC RETURN

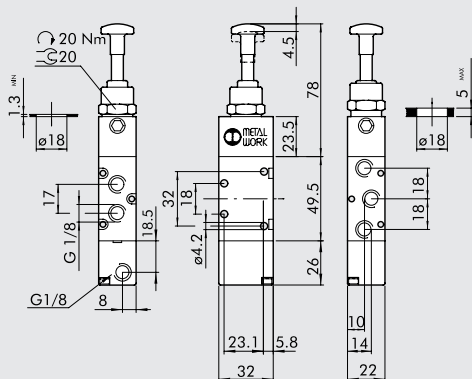

Symbol	Code	Abbrev.	Weight [g]
	8287369	MAV 25 PPP NC	174

NOTES

VALVES SERIES 70, MECHANICALLY OPERATED, 1/8" ADDITION TO THE CATALOGUE



TECHNICAL DATA

Thread at valve ports		1/8"
Operation force at 6 bar:		
• Version with direct control	N	50
• Pilot-assisted Version	N	6
Operating pressure:		
• Version with direct control	bar	from vacuum to 10
• Pilot-assisted version	bar	from 2.5 to 10
Operating temperature range	°C	from -10 to +60
Nominal diameter	mm	5
Conductance C	Nl/min · bar	121.43
Critical ratio b	bar/bar	0.32
Flow rate at 6 bar ΔP 0.5 bar	Nl/min	400
Flow rate at 6 bar ΔP 1 bar	Nl/min	550



SYNOPTIC, SIZES AND VERSION

MEV	2	3	T A	S	NC
FAMILY	DIMENSIONS	FUNCTION	OPERATORS 14	RESETTING (12)	FURTHER DETAILS
MEV mechanically operated valves	2 1/8"	3 3/2 5 5/2	TA plunger BR bidirectional roller UR unidirectional roller TS sensitive plunger RS sensitive roller AS sensitive aerial LL frontal roller lever LV unidirectional lever LS sensitive lever LR extended roller lever	S mechanical springs A pneumatic/mechanical spring* P pneumatic B bistable	NC normally closed OO 5/2 SP special
				*on demand	

PLUNGER 3/2, 1/8" PNEUMATIC RETURN

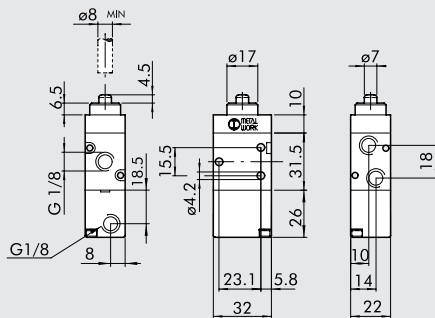

PLUNGER 3/2, 1/8" FOR FIXING TO PANEL

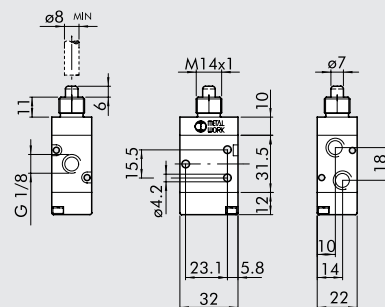

Symbol	Code	Abbrev.	Weight [g]
	8825961	MEV 23 TAP OO	102

Symbol	Code	Abbrev.	Weight [g]
	8829123	MEV 23 TAS SP	102

DOUBLE ROLLER LEVER 3/2, 1/8"

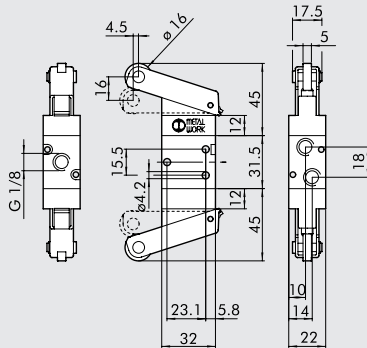

Symbol	Code	Abbrev.	Weight [g]
	7001000530	MEV 23 BRB OO	223

DOUBLE ROLLER LEVER 5/2, 1/8"

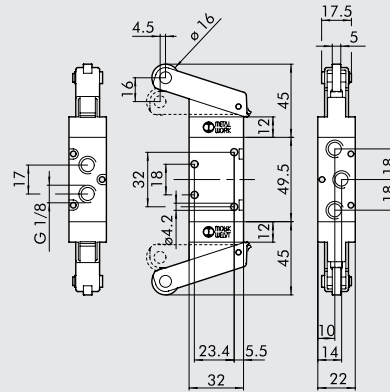

Symbol	Code	Abbrev.	Weight [g]
	7001000540	MEV 25 BRB OO	285

PILOT-ASSISTED DOUBLE ROLLER LEVER 5/2, 1/8"

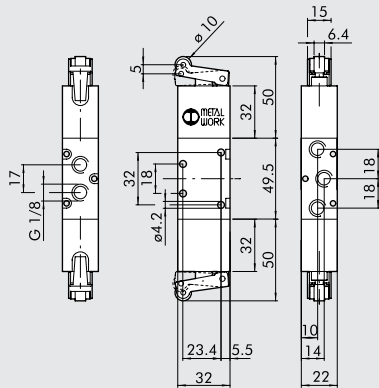

Symbol	Code	Abbrev.	Weight [g]
	7001000430	MEV 23 RSB OO	255

PILOT-ASSISTED LEVER WITHOUT ROLLER 5/2, 1/8"

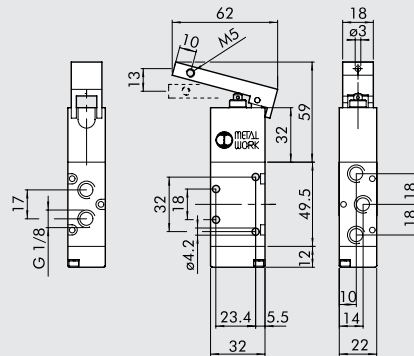

Symbol	Code	Abbrev.	Weight [g]
	7001000411	MEV 25 LSS OO	209

EXTENDED PILOT-ASSISTED ROLLER LEVER 5/2, 1/8"

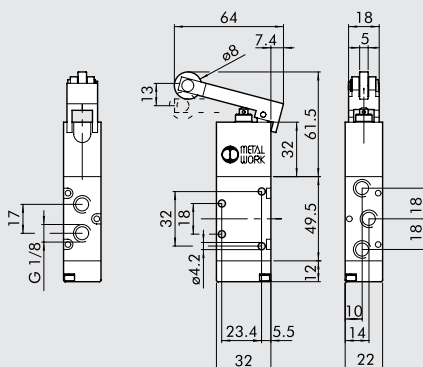

Symbol	Code	Abbrev.	Weight [g]
	7001000412	MEV 25 LRS OO	213

NOTES

VALVES SERIES 70, SOLENOID/PNEUMATIC ADDITION TO THE CATALOGUE



TECHNICAL DATA		1/8"	1/4"	1/2"
Operating pressure:				
• monostable	bar	from 2.5 to 10		
• bistable	bar	from 1 to 10		
• asserved	bar	from vacuum to 10		
Minimum pilot pressure	bar	2.5		
Operating temperature range	°C	from -10 to +60		
Nominal diameter	mm	5	7.5	15
Conductance C	Nl/min · bar	121.43	264.26	971.43
Critical ratio b	bar/bar	0.32	0.27	0.43
Flow rate at 6 bar ΔP 0.5 bar	Nl/min	400	750	3200
Flow rate at 6 bar ΔP 1 bar	Nl/min	550	1100	4600
TRA / TRR monostable at 6 bar	ms	15/35	19/45	36/60
TRA / TRR bistable at 6 bar	ms	20/20	21/21	30/30
Hand operation		bistable		
Coil voltage values		24VDC - 24VAC - 110VAC - 220VAC 50/60Hz		
Power		2 W (DC) 3VA (AC)		2 W (DC) 3VA (AC) 5W (DC) 5VA (AC)
Voltage tolerance	%	from -10 to +15		
Insulation class		F 155		
Maximum coil nut torque	Nm	1		



VALVES

SYNOPTIC, SIZES AND VERSION

SO V		2		3		SO		S		NC	
FAMILY		DIMENSIONS		FUNCTION		OPERATORS 14		RESETTING (12)		FURTHER DETAILS	
SOV	solenoid/ pneumatic	2	1/8"	3	3/2	SO	solenoid	S	mechanical springs	NC	normally closed
		3	1/4"	5	5/2	SE	solenoid assisted	B	bistable	NO	normally open
		4	1/2"	6	5/3			D	differential	CC	closed centres
								P	pneumatic	OC	open centres
								A	pneumatic/mechanical spring*	PC	pressure centres
								L	pneumatic spring	OO	5/2
										SP	special

*on demand

VALVES SERIES 70, SOLENOID/PNEUMATIC, PILOT-ASSISTED SOLENOID/PNEUMATIC, 1/8"

ELECTRO-PNEUMATIC 3/2, NC 1/8" PNEUMATIC RETURN

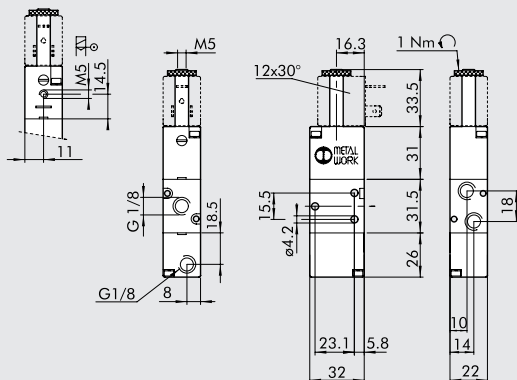

ELECTRO-PNEUMATIC 5/2, 1/8" PNEUMATIC RETURN

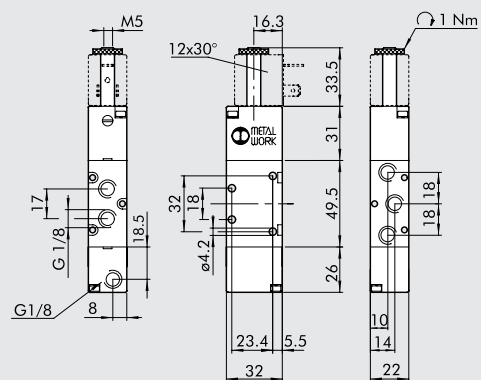

Symbol	Code	Abbrev.	Weight [g]
	7010020800	SOV 23 SOP NC	114
	7010020510	SOV 23 SEP NC	114

Symbol	Code	Abbrev.	Weight [g]
	7010021501	SOV 25 SOP OO	142

VALVES SERIES 70, SOLENOID/PNEUMATIC - ADDITION TO THE CATALOGUE

ELECTRO-PNEUMATIC 5/3, 1/8" PNEUMATIC RETURN

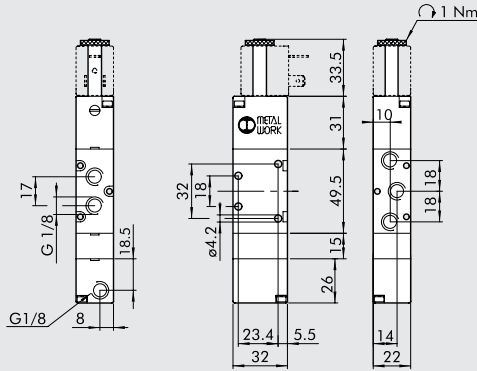

Symbol	Code	Abbrev.	Weight [g]
	7010022800	SOV 26 SOP CC	204

BISTABLE DIFFERENTIAL 3/2, 1/8"

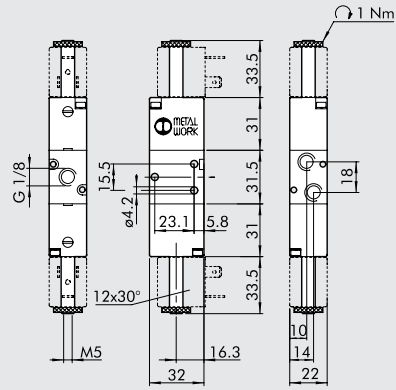

Symbol	Code	Abbrev.	Weight [g]
	8287210	SOV 23 SOD NC	135

MONOSTABLE 3/2, NC 1/8" HAND-OPERATED ON THE FEED SIDE

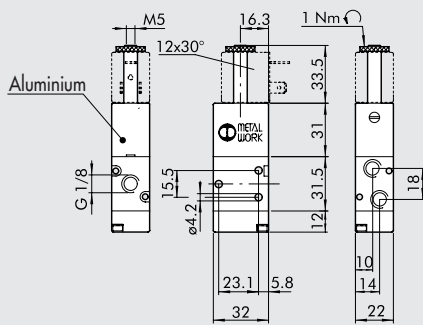

Symbol	Code	Abbrev.	Weight [g]
	8830195	SOV 23 SOS SP	100

MONOSTABLE 5/2, 1/8" HAND-OPERATED ON THE FEED SIDE

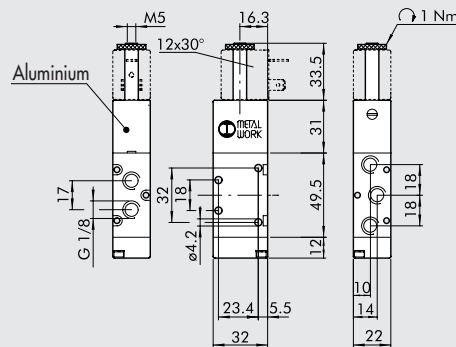

Symbol	Code	Abbrev.	Weight [g]
	8286807	SOV 25 SOS SP	128

BISTABLE 5/2, 1/8" HAND-OPERATED ON THE FEED SIDE

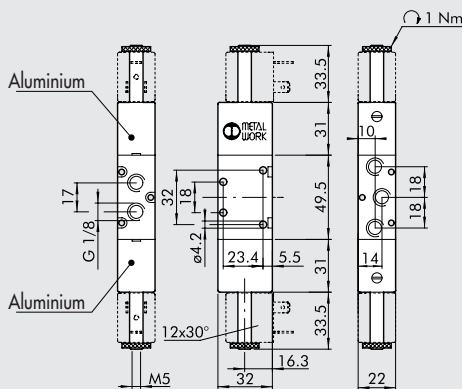

Symbol	Code	Abbrev.	Weight [g]
	8286808	SOV 25 SOB SP	160

MONOSTABLE 5/3, 1/8" HAND-OPERATED ON THE FEED SIDE

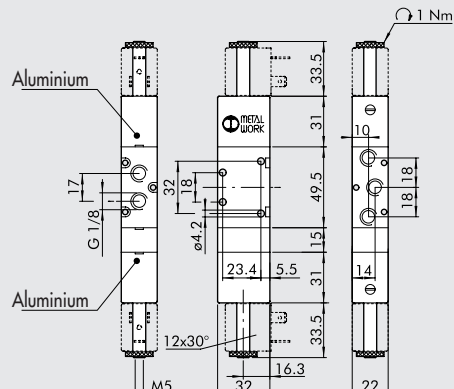

Symbol	Code	Abbrev.	Weight [g]
	8286911	SOV 26 SOS SP	190

VALVES SERIES 70, SOLENOID/PNEUMATIC, PILOT-ASSISTED SOLENOID/PNEUMATIC, 1/4"

ELECTRO-PNEUMATIC 3/2, 1/4" PNEUMATIC RETURN

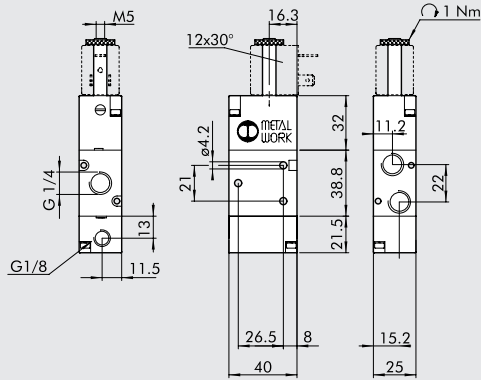

Symbol	Code	Abbrev.	Weight [g]
	7020020800	SOV 33 SOP OO	166

ELECTRO-PNEUMATIC 5/2, 1/4" PNEUMATIC RETURN

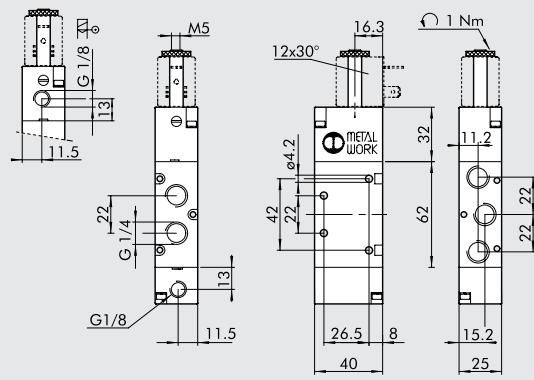

Symbol	Code	Abbrev.	Weight [g]
	7020021700	SOV 35 SOP OO	214
	7020021800	SOV 35 SEP OO	214

VALVES SERIES 70, SOLENOID/PNEUMATIC, PILOT-ASSISTED SOLENOID/PNEUMATIC, 1/2"

MONOSTABLE 3/2, NO 1/2", PNEUMATIC SPRING

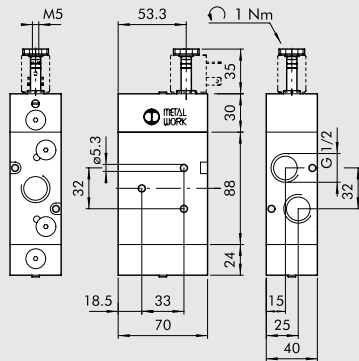

Symbol	Code	Abbrev.	Weight [g]
	7030020820	SOV 43 SOL NO	940

MONOSTABLE 5/2, NO 1/2", PNEUMATIC SPRING

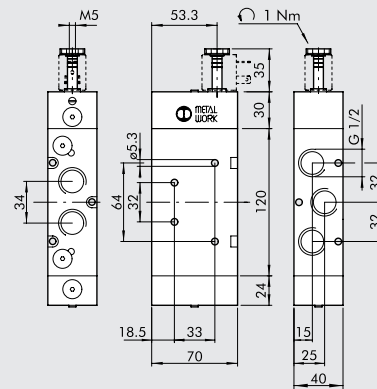

Symbol	Code	Abbrev.	Weight [g]
	7030021820	SOV 45 SOL OO	1120

ELECTRO-PNEUMATIC 3/2 NC, 1/2" PNEUMATIC RETURN

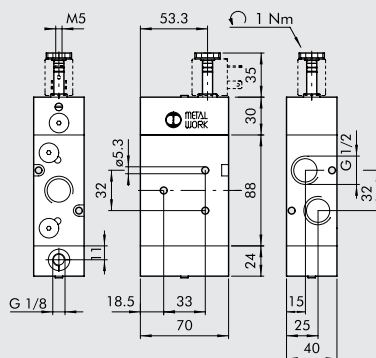

Symbol	Code	Abbrev.	Weight [g]
	7030020201	SOV 43 SOP NC	930

NOTES

REPOSITIONING FOR VALVES SERIES 70

MONOSTABLE WITH "S" MECHANICAL SPRING RETURN

When the solenoid pilot deactivates, the valve is switched by a mechanically-operated spring.

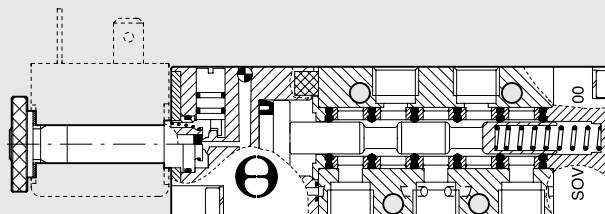

MONOSTABLE WITH "L" PNEUMATIC SPRING RETURN

When the solenoid valve is actuated, the valve switches when the diameter of the control piston is greater than that of the pneumatic spring piston.

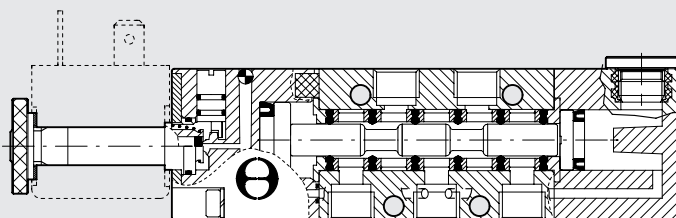

BISTABLE WITH SOLENOID CONTROL AND "P" PNEUMATIC CONTROL

When the solenoid valve is actuated, the valve only switches when pressure is cut out from the pneumatic control, because both pistons have the same diameter.

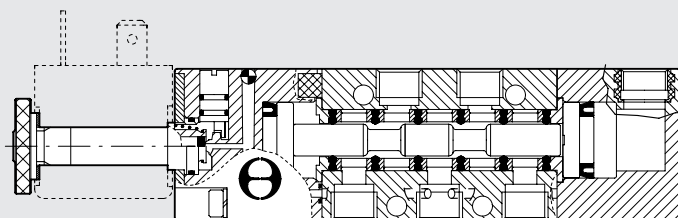

PILOT WITH THROUGH BASE



The base has a through hole with push-in fittings for a Ø 6 pipe. A 3/2 NC solenoid pilot is mounted on the base, and the output port is connected to a push-in fitting for a Ø 4 pipe. A silencer is mounted on the pilot drain side. The unit comes complete with a 22-mm coil.

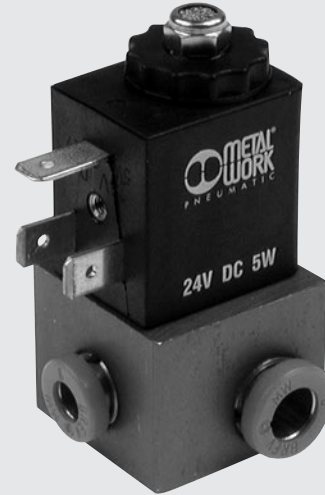

VALVES

PILOT WITH THROUGH BASE

DIMENSIONS AND ORDERING CODES

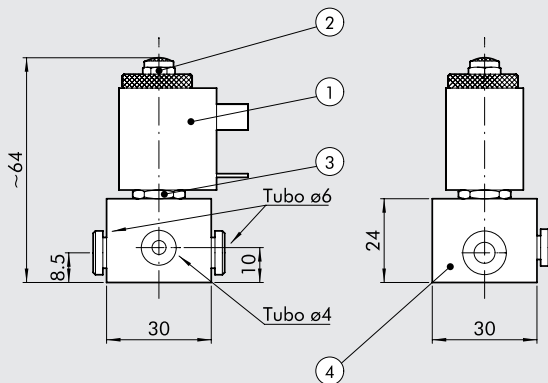

- ① 22 mm coil, Ø 8 5W-24 VDC
- ② Silencer
- ③ 3/2 Pilot, NC 5W:
 - Bore 1.1 mm
 - Max application pressure 10 Bar
- ④ Body made of anodised aluminium

Code	Description
8826323	Special 3/2 pilot

PNEUMATIC SYSTEM DIAGRAM

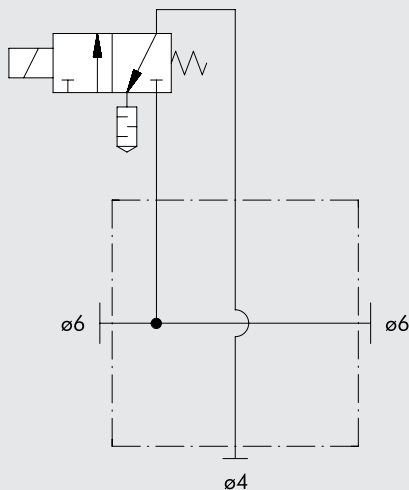

NOTES

MACH 16 VALVES FOR SECONDARY MULTIPLE CONNECTOR

In this valve, the distance between the centre line of the body and the electric connector is greater than in a standard valve (79 mm instead of 69 mm), allowing connection to the secondary electrical connector. The increased flexibility of the Mach 16 system makes it possible to arrange units with a greater number of valves.

For example:

- unit with 4 bistable and 8 monostable valves
- unit with 16 monostable valves

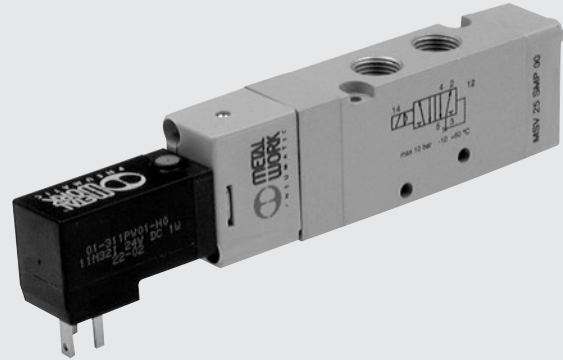

VALVES

MACH 16 VALVES FOR SECONDARY MULTIPLE CONNECTOR

5/2 MONOSTABLE SOLENOID, PNEUMATIC SPRING FOR SECONDARY CONNECTOR

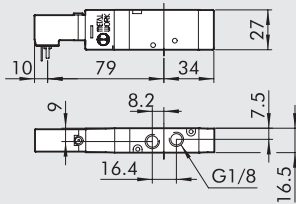

Symbol	Code	Abbrev.	Weight [g]
	8826189	MSV 25 SSP 00	110

EXAMPLE OF APPLICATION

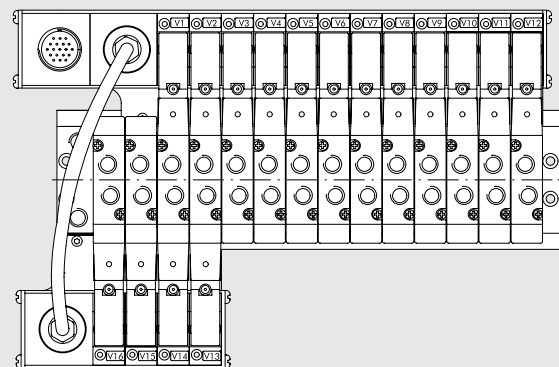
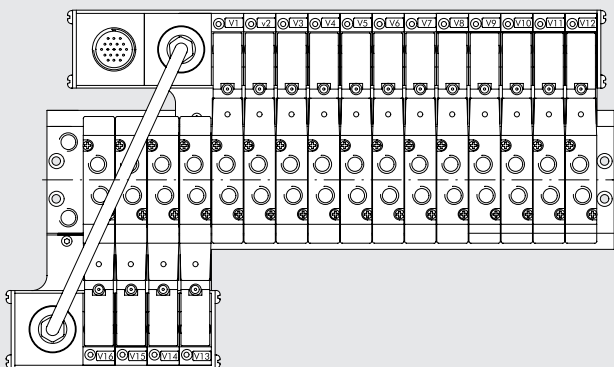

MULTIPLE BASES FOR MACH 18 VALVES



These multiple bases come complete with cartridges and push-in fitting for $\varnothing 6$ pipes on all output ports.

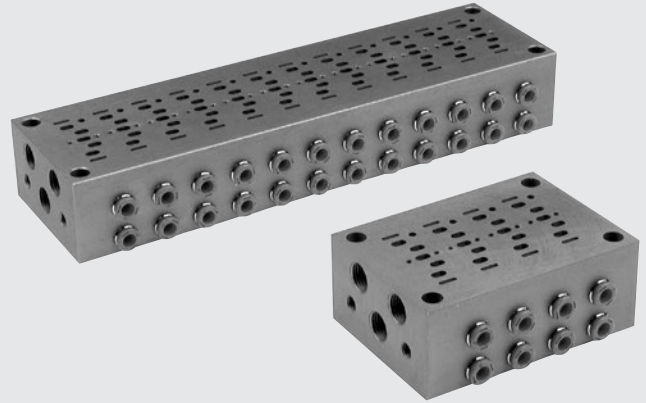

VALVES

MULTIPLE BASES FOR MACH 18 VALVES

DIMENSIONS AND ORDERING CODES

4 POSITIONS

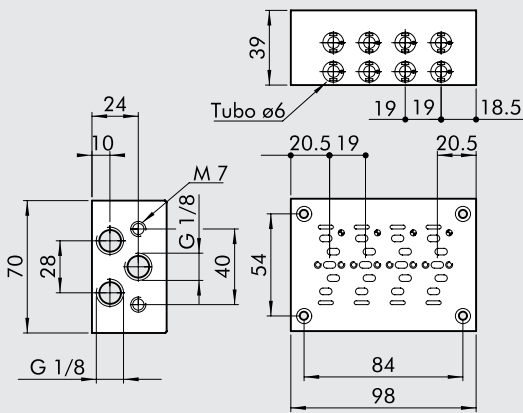

8 POSITIONS

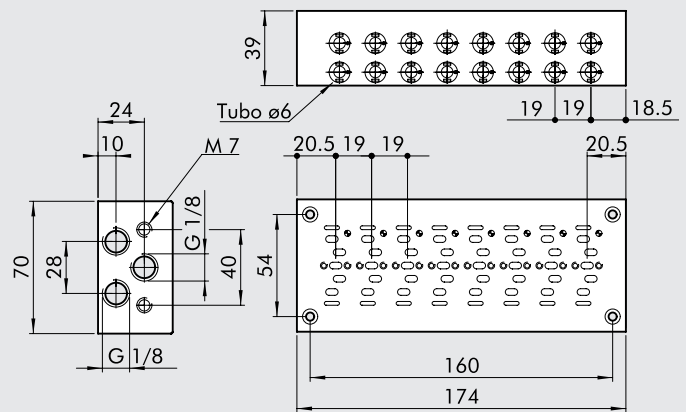

12 POSITIONS

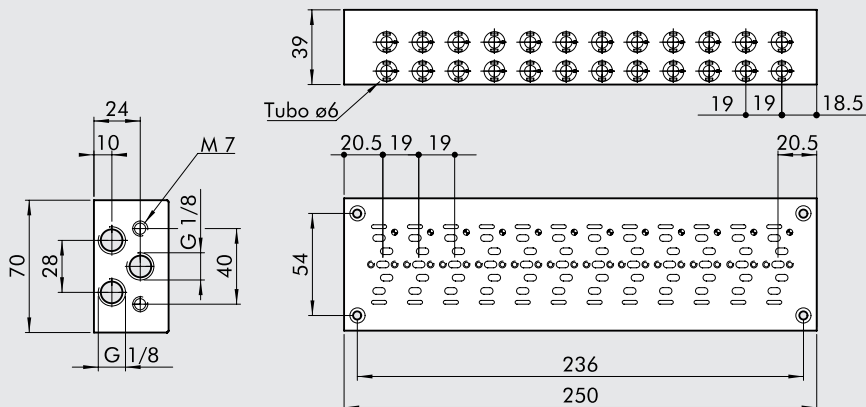

Code	Description	Weight [g]
8826176	4-position base	660
8826177	8-position base	1190
8826178	12-position base	1720

VALVES ISO 5599/1, PNEUMATIC SERIES IPV ADDITION TO THE CATALOGUE

TECHNICAL DATA		ISO 1	ISO 2	ISO 3
Operating pressure	bar	from vacuum to 10		
Minimum operation pressure:				
• monostable	bar	2.5		
• bistable	bar	1		
Operating temperature range	°C	from -10 to +60		
Nominal diameter	mm	7.5	12	15
Conductance C	Nl/min · bar	250	657.14	971.43
Critical ratio b	bar/bar	0.36	0.25	0.43
Flow rate at 6 bar ΔP 0.5 bar	Nl/min	700	1800	3200
Flow rate at 6 bar ΔP 1 bar	Nl/min	1100	2700	4600
Response times at 6 bar:				
• monostable	ms	12	24	35
• bistable	ms	20	30	45
Repositioning response times at 6 bar:				
• monostable	ms	30	43	55
• bistable	ms	20	30	45
Manual		Monostable on valve body		



SYNOPTIC, SIZES AND VERSION

IPV FAMILY		5 DIMENSIONS		5 FUNCTION		PN OPERATORS 14		S RESETTING (12)		OO FURTHER DETAILS	
IPV	ISO pneumatic	5	ISO 1	5	5/2	PN	pneumatic	S	mechanical springs	OO	5/2
		6	ISO 2	6	5/3			B	bistable	CC	closed centres
		7	ISO 3					D	differential	OC	open centres
								L	pneumatic spring	PC	pressure centres
										SP	special

PNEUMATIC ACTUATION - ISO 1 PNEUMATIC SPRING

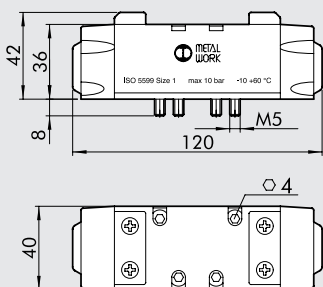

Symbol	Code	Abbrev.	Weight [g]
	7051011420	IPV 55 PNL OO	310

PNEUMATIC ACTUATION - ISO 2 PNEUMATIC SPRING

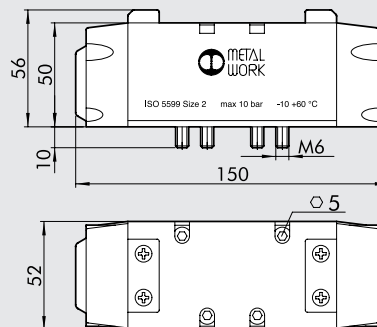

Symbol	Code	Abbrev.	Weight [g]
	7052011420	IPV 65 PNL OO	705

ANTI-STALL PNEUMATIC ACTUATION

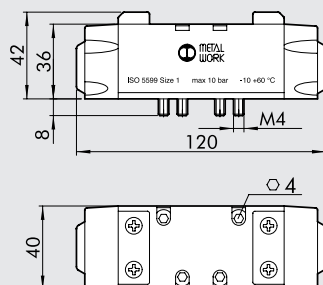

Symbol	Code	Abbrev.	Weight [g]
	8294645	IPV 55 PNB SP	310

The valve normally switches when it is actuated, irrespective of the spool position.
NB. M4 screws are not to ISO 5599

VALVES ISO 5599/1, SOLENOID/PNEUMATIC, SERIES ISV ADDITION TO THE CATALOGUE



TECHNICAL DATA		ISO 1	ISO 2	ISO 3
Operating pressure:	bar			
• monostable	bar	from 2.5 to 10		
• bistable	bar	from 1 to 10		
• pilot-assisted	bar	from vacuum to 10		
Minimum pilot pressure	bar	2.5		
Operating temperature range	°C	from -10 to +60		
Nominal diameter	mm	7.5	12	15
Conductance C	NI/min · bar	250	657.14	971.43
Critical ratio b	bar/bar	0.36	0.25	0.43
Flow rate at 6 bar ΔP 0.5 bar	NI/min	700	1800	3200
Flow rate at 6 bar ΔP 1 bar	NI/min	1100	2700	4600
TRA / TRR monostable at 6 bar	ms	24 / 50	39 / 60	50 / 120
TRA / TRR bistable at 6 bar	ms	20 / 20	25 / 25	35 / 35
Solenoid pilot		Standards CNOMO		
Manual		Bistable on solenoid pilot Monostable on valve body		
Coils		30 mm side DIN 43650 Form A - ISO 4400 22 mm side		
Maximum coil nut torque	Nm	1		



VALVES

SYNOPTIC, SIZES AND VERSION

ISV FAMILY		5 DIMENSIONS		3 FUNCTION		SO OPERATORS 14		S RESETTING (12)		OO FURTHER DETAILS	
ISV	solenoid/pneumatic	5	ISO 1	5	5/2	SO	solenoid	S	mechanical springs	OO	5/2
		6	ISO 2	6	5/3	SE	solenoid assisted	B	bistable	CC	closed centres
		7	ISO 3					D	differential	OC	open centres
								L	pneumatic spring	PC	pressure centres
										SP	special

MONOSTABLE 5/2, ISO 1 PNEUMATIC RETURN – PNEUMATIC SPRING

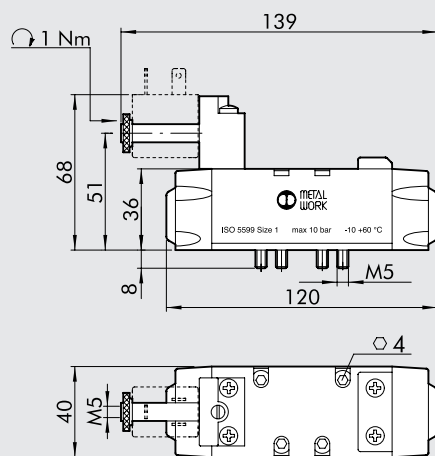

MONOSTABLE 5/2, ISO 2 PNEUMATIC RETURN

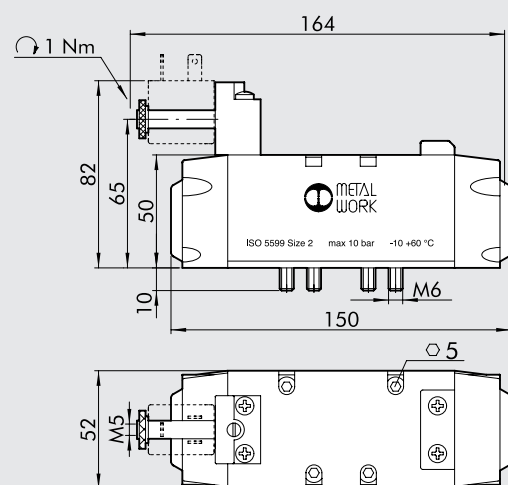

Symbol	Code	Abbrev.	Weight [g]
	7051021700	ISV 55 SOP OO	344
	8293307	ISV 55 SOL OO	344

Symbol	Code	Abbrev.	Weight [g]
	7052021700	ISV 65 SOP OO	715

VALVES ISO 5599/1, SOLENOID/PNEUMATIC, SERIES ISV - ADDITION TO THE CATALOGUE

SUMMARY OF VALVE ISLANDS AND FIELDBUS



● **HDM FOR THE SPLASH AREA**

B2.2



● **MULTIMACH WITH FRONT ATTACHMENT**

B2.4

HDM FOR THE SPLASH AREA

A flange made of technopolymer with an EPDM foam gasket separates the fitting area, called the splash area, from the valves.

The valves are standard HDM for \varnothing 6mm pipes. The input end plate and the blind end plate are designed to be fixed onto the base.

Please refer to the standard HDM catalogue for full technical details.

Islands with 4, 6 or 8 valves can be provided.

The dimensions of the base are the same in all cases.



AVAILABLE COMPONENTS

- **End plate 1-25D spec:** end plate with supply port, \varnothing 10 mm pipe and 25-pin connector.
- **End plate 1 + pilot-25D spec.:** end plate with supply port, \varnothing 10 mm pipe, separate pilot (\varnothing 4 mm pipe) and 25-pin connector.
- **End plate 1 Profibus-DP spec.:** end plate with supply port, \varnothing 10 mm pipe and Profibus connection.
- **End plate 1 + Profibus -DP pilot spec.:** end plate with supply port, \varnothing 10 mm pipe, separate pilot (\varnothing 4 mm pipe) and Profibus connection.
- **Valves:** the solenoid valves are standard HDM with \varnothing 6 mm pipe.
- **Special blind end plate:** special blind end plate for fixing to the plate.
- **Intermediate blind 7R:** blind intermediate end plate with separate supply and discharge ports, \varnothing 6 mm pipes, width 11.5 mm. The intermediate end plate is installed instead of a valve, so there can be 3, 5 or 7 valves.

EXAMPLE OF AN ORDERING CODE

HDM for splash area; End plate 1+ Profibus-DP pilot; V6-V6-V6-7R-16-16-5.

An island will be supplied with an input end plate with separate supply and pilot, Profibus connection, three 5/2 monostable valves, one blind intermediate end plate, two 3/2 NC dual valves and one blind end plate.

DIMENSIONS

HDM

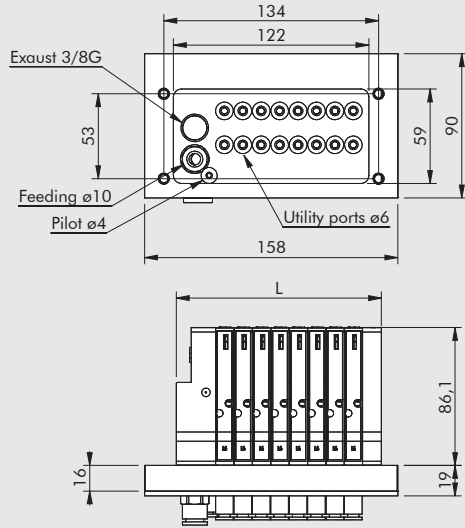

No. valves	L
4	82.4
6	105.2
8	128

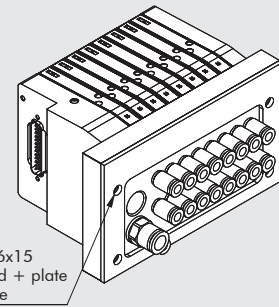
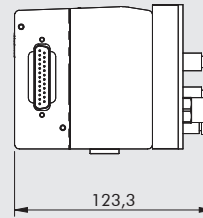

N° 4 holes M6x15 fixing of island + plate to the structure

HDM + PROFIBUS

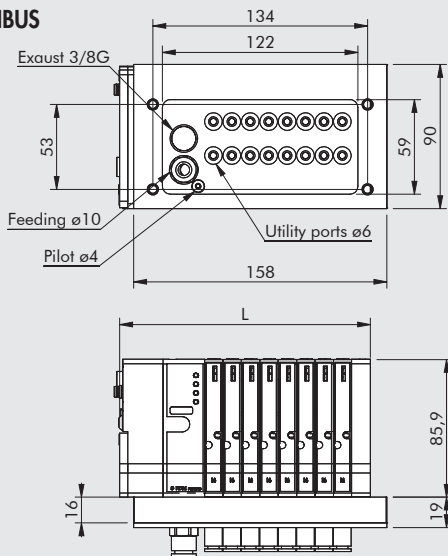

No. valves	L
4	110.9
6	133.7
8	156.5

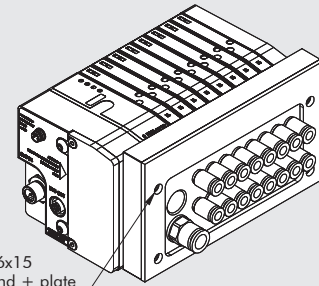
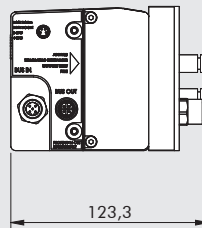

n 4 holes M6x15 fixing of island + plate to the structure

AVAILABLE ISLANDS

8 positions

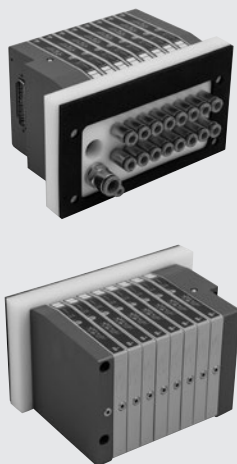

6 positions



4 positions

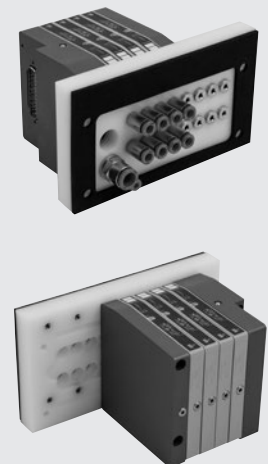

MULTIMACH WITH FRONT ATTACHMENT

There are M5 threaded holes at the front of terminal 1-11 and the blind terminal that allow the panel-type unit to be mounted as shown in the photo.

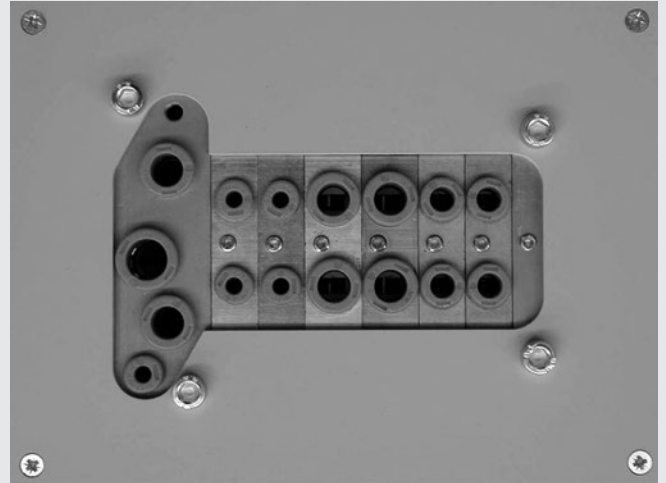

VALVES

MULTIMACH WITH FRONT ATTACHMENT

TERMINAL 1-11 FRONT ATTACHMENT

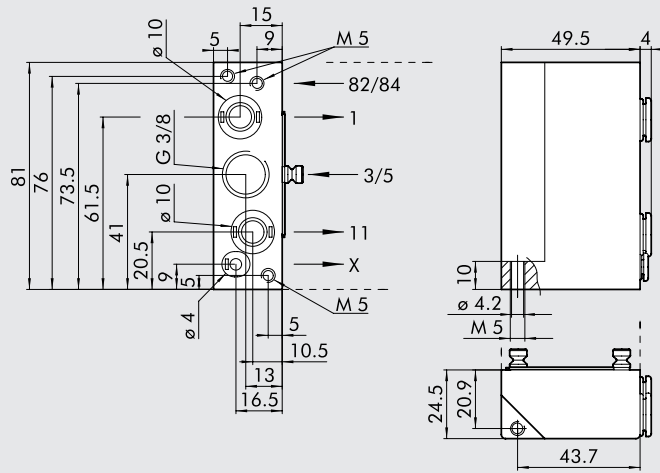

Code	Description
0227300202	Kit terminal 1-11 front attachment

BLIND TERMINAL - FRONT ATTACHMENT

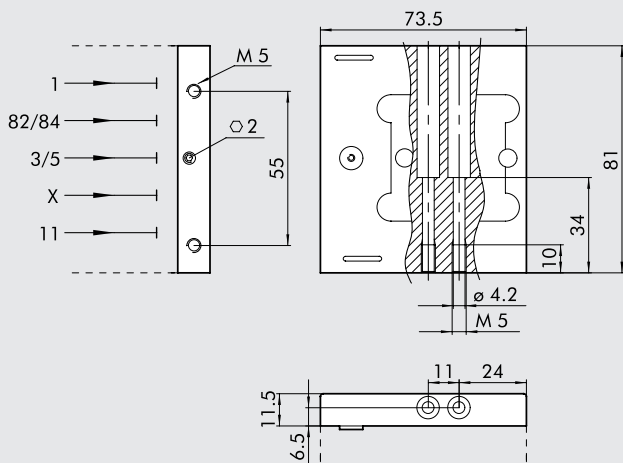

Code	Description
0227300501	Blind terminal and front attachment kit