



S50-PA/MA...W

Contrast sensor

INSTRUCTION MANUAL

CONTROLS

OUTPUT LED

The yellow LED on indicates that the N.O. (normally open) output status is closed.

READY/ERROR LED (bicolour)

When the bicoloured LED is continuously green, the sensor is operating in a normal condition and it is ready to function correctly (stability condition).

The red and green blinking of the LED indicates a wrong sensor setting. Please refer to the "SETTING" paragraph to get the correct setting procedure.

SET PUSHBUTTON

A long pressure on the pushbutton activates the self-setting procedure.

INSTALLATION

S50-PA...W: The sensor can be fixed by means of the M18x1 threaded body through a \varnothing 18 mm hole, using the specific washer and the enclosed 24 mm nuts (maximum torque of tightening 1.5 Nm). Alternatively, the sensor can be mounted through the two housing's holes using two screws (M3x22 or longer) and nuts. Amongst the various possible solutions, we suggest to choose the combination that offers the best visibility of the signalling Leeds and the easiest access to the SET pushbutton.

22 mm nuts, h=8 mm, (2 Nm maximum tightening torque) are available to guarantee an improved torque.

S50-MA...W: The sensor can be fixed by means of the M18x1 threaded body through a \varnothing 18 mm hole, using the specific washer and the two CH.24 nuts enclosed (22 Nm maximum tightening torque).

For both plastic version and metallic version are available various orientable fixing brackets to ease the sensor positioning (please refer to the accessories listed in the general catalogue).

The operating distance is measured from the front surface of the sensor lens.

CONNECTIONS

The connections are compliant to the EN 60947-5-2 standard.

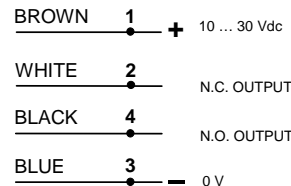

M12 CONNECTOR

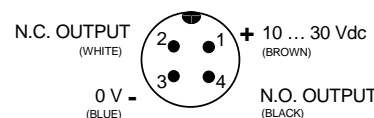

DIMENSIONS

S50-PA VERSIONS

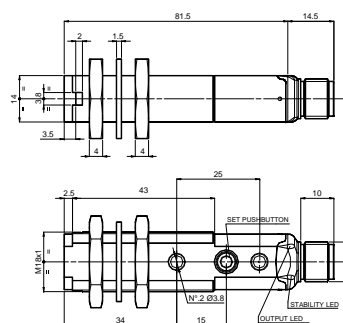

S50-MA VERSIONS

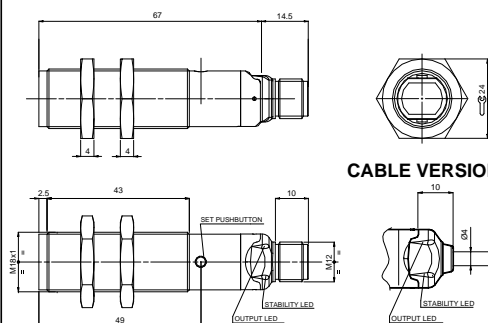

TECHNICAL DATA

	S50-PA PLASTIC VERSIONS	S50-MA METALLIC VERSIONS
Power supply:	10 ... 30 Vdc (limit values)	
Ripple:	2 Vpp max.	
Current consumption (output current excluded):	25 mA max.	
Outputs:	N.O. and N.C.: PNP or NPN; 30 Vcc max. (short-circuit protection)	
Output current:	100 mA max.	
Output saturation voltage:	2 V max.	
Response time:	100 μ s	
Switching frequency:	5 kHz	
Indicators:	OUTPUT LED (YELLOW) / LED READY/ERROR (GREEN/RED)	
Setting:	SET pushbutton	
Operating mode:	LIGHT mode on N.O. output / DARK mode on N.C. output	
Data retention:	non volatile EEPROM memory	
Operating temperature:	-10 ... 55 °C	
Storage temperature:	-20 ... 70 °C	
Insulating strength:	500 Vac 1 min., between electronics and housing	
Insulating resistance:	>20 M Ω 500 Vdc, between electronics and housing	
Operating distance (typical values):	10 mm \pm 2 mm	
Minimum spot dimension:	4.5 mm	
Emission type:	white light LED (400-700 nm)	
Ambient light rejection:	according to EN 60947-5-2	
Vibrations:	0.5 mm amplitude, 10 ... 55 Hz frequency, for every axis (EN60068-2-6)	
Shock resistance:	11 ms (30 G) 6 shock for every axis (EN60068-2-27)	
Housing:	PBT	Nickel plated brass
Lenses:	PMMA	
Mechanical protection:	IP67 Metal versions type 1 enclosure	
Connections:	2 m cable \varnothing 4 mm / M12 - 4 pole connector	
Weight:	75 g. max. cable vers. 25 g. max. connector vers.	110 g. max. cable vers. 60 g. max. connector vers.
AtEx 2014/34/EU	II 3G EX nA II T6; II 3D EX tD A22 IP67 T85°C	

SETTING

EASY TOUCH™

The sensor uses the patent-covered EASY TOUCH™ technology that allows a rapid and safe self-setting of the product.

Two different setting possibilities are available:

- **EASY TOUCH™**; a long pressure of the SET pushbutton allows self-setting.
- **FINE DETECTION**; to be used only in particularly critical conditions, this setting procedure is used only when the EASY TOUCH™ is not sufficient.

Setting of S50-PA/MA...W

To achieve a correct sensor functioning, the coloured mark or object to be detected has to be placed at the right reading distance.

- **EASY TOUCH™ (standard detection in the DARK mode)**

The EASY TOUCH™ technology allows the functioning in the DARK mode (mark presents a lower light intensity respect to the background).

The mark to detect has to be placed correctly at the right reading distance within the sensor spot.

Press the SET pushbutton until the READY/ERROR LED turns OFF.

Release the SET pushbutton and wait for the READY/ERROR LED to turn green.

The sensor is now ready to detect the pre-set coloured mark or object (output LED turns ON when the N.O. output is closed).

- **Fine detection (DARK or LIGHT mode)**

This mode offers an improved detection precision.

The sensor can function either in the DARK operating or in the LIGHT operating mode (light-coloured mark ON dark background).

The operating mode is selected automatically by the sensor.

The mark to detect has to be placed correctly at the right reading distance within the sensor spot.

Press the SET pushbutton. The READY/ERROR LED turns OFF.

Keep the SET pushbutton pressed until the READY/ERROR LED blinks green. Place the background under the sensor spot.

Press the SET pushbutton again until the READY/ERROR LED turns OFF.

The sensor is now ready to detect, with a very high precision, the pre-set coloured mark (output LED turns ON, READY/ERROR LED turns green).

The output LED is ON and the N.O. output is closed, when the sensor is positioned on the pre-set coloured mark.

NOTE

If a setting error will occur please repeat again the EASY TOUCH setting procedure, in order to be sure to restart the setting procedure correctly.

Datalogic S.r.l.

Via S. Vitalino 13 - 40012 Calderara di Reno - Italy
Tel: +39 051 3147011 - Fax: +39 051 3147205 - www.datalogic.com

Helpful links at www.datalogic.com: **Contact Us, Terms and Conditions, Support.**

The warranty period for this product is 36 months. See General Terms and Conditions of Sales for further details.

Under current Italian and European laws, Datalogic is not obliged to take care of product disposal at the end of its life. Datalogic recommends disposing of the product in compliance with local laws or contacting authorised waste collection centres.

© 2007 - 2017 Datalogic S.p.A. and/or its affiliates • ALL RIGHTS RESERVED. • Without limiting the rights under copyright, no part of this documentation may be reproduced, stored in or introduced into a retrieval system, or transmitted in any form or by any means, or for any purpose, without the express written permission of Datalogic S.p.A. and/or its affiliates. Datalogic and the Datalogic logo are registered trademarks of Datalogic S.p.A. in many countries, including the U.S.A. and the E.U. All other trademarks and brands are property of their respective owners. Datalogic reserves the right to make modifications and improvements without prior notification.