

WAGO → I/O → SYSTEM 750

Fieldbus Independent I/O Modules

4 DI DC 5 V 0.2 ms, High-Side
Switching
750-414



Manual

Version 1.0.5

Copyright © 2008 by WAGO Kontakttechnik GmbH & Co. KG
All rights reserved.

WAGO Kontakttechnik GmbH & Co. KG

Hansastraße 27
D-32423 Minden

Phone: +49 (0) 571/8 87 – 0
Fax: +49 (0) 571/8 87 – 1 69
E-Mail: info@wago.com
Web: <http://www.wago.com>

Technical Support

Phone: +49 (0) 571/8 87 – 5 55
Fax: +49 (0) 571/8 87 – 85 55
E-Mail: support@wago.com

Every conceivable measure has been taken to ensure the correctness and completeness of this documentation. However, as errors can never be fully excluded, we would appreciate any information or ideas at any time.

E-Mail: documentation@wago.com

We wish to point out that the software and hardware terms as well as the trademarks of companies used and/or mentioned in the present manual are generally trademark or patent protected.

Content

1 Important Notes	4
1.1 Legal Bases.....	4
1.1.1 Copyright.....	4
1.1.2 Personnel Qualifications.....	4
1.1.3 Use of the 750 Series in Compliance with Underlying Provisions	5
1.1.4 Technical Condition of Specified Devices	5
1.2 Standards and Guidelines for Operating the 750 Series.....	6
1.3 Symbols	7
1.4 Safety Information.....	8
1.5 Font Conventions	9
1.6 Number Notation.....	9
1.7 Scope	9
2 I/O Modules	10
2.1 Digital Input Modules	10
2.1.1 750-414 [4 DI DC 5 V 0.2 ms, High-Side Switching]	10
2.1.1.1 View	10
2.1.1.2 Description.....	10
2.1.1.3 Display Elements	11
2.1.1.4 Schematic Diagram.....	12
2.1.1.5 Technical Data	12
2.1.1.6 Process Image	14
3 Use in Hazardous Environments	15
3.1 Marking Configuration Examples	16
3.1.1 Marking for Europe according to CENELEC and IEC	16
3.1.2 Marking for America according to NEC 500	19
3.2 Installation Regulations.....	20
3.2.1 Special Conditions for Safe Operation of the ATEX and IEC Ex (acc. DEMKO 08 ATEX 142851X and IECEx PTB 07.0064).....	21
3.2.2 Special conditions for safe use (ATEX Certificate TÜV 07 ATEX 554086 X).....	22
3.2.3 Special conditions for safe use (IEC-Ex Certificate TUN 09.0001 X)24	
3.2.4 Special conditions for safe use (ATEX Certificate DEKRA 11ATEX0203 X)	26
3.2.5 ANSI/ISA 12.12.01	27

1 Important Notes

This section includes an overall summary of the most important safety requirements and notes that are mentioned in each individual section. To protect your health and prevent damage to devices as well, it is imperative to read and carefully follow the safety guidelines.

1.1 Legal Bases

1.1.1 Copyright

This Manual, including all figures and illustrations, is copyright-protected. Any further use of this Manual by third parties that violate pertinent copyright provisions is prohibited. Reproduction, translation, electronic and phototechnical filing/archiving (e.g., photocopying) as well as any amendments require the written consent of WAGO Kontakttechnik GmbH & Co. KG, Minden, Germany. Non-observance will involve the right to assert damage claims.

WAGO Kontakttechnik GmbH & Co. KG reserves the right to provide for any alterations or modifications that serve to increase the efficiency of technical progress. WAGO Kontakttechnik GmbH & Co. KG owns all rights arising from the granting of patents or from the legal protection of utility patents. Third-party products are always mentioned without any reference to patent rights. Thus, the existence of such rights cannot be excluded.

1.1.2 Personnel Qualifications

The use of the product described in this Manual requires special personnel qualifications, as shown in the following table:

Activity	Electrical specialist	Instructed personnel*)	Specialists**) having qualifications in PLC programming
Assembly	X	X	
Commissioning	X		X
Programming			X
Maintenance	X	X	
Troubleshooting	X		
Disassembly	X	X	

*) Instructed persons have been trained by qualified personnel or electrical specialists.

**) A specialist is a person, who – thanks to technical training – has the qualification, knowledge and expertise to meet the required specifications of this work and to identify any potential hazardous situation in the above listed fields of activity.

All responsible persons have to familiarize themselves with the underlying legal standards to be applied. WAGO Kontakttechnik GmbH & Co. KG does not assume any liability whatsoever resulting from improper handling and damage incurred to both WAGO's own and third-party products by disregarding detailed information in this Manual.

1.1.3 Use of the 750 Series in Compliance with Underlying Provisions

Couplers, controllers and I/O modules found in the modular WAGO-I/O-SYSTEM 750 receive digital and analog signals from sensors and transmit them to the actuators or higher-level control systems. Using programmable controllers, the signals can also be (pre-)processed.

The components have been developed for use in an environment that meets the IP20 protection class criteria. Protection against finger injury and solid impurities up to 12.5 mm diameter is assured; protection against water damage is not ensured. Unless otherwise specified, operation of the components in wet and dusty environments is prohibited.

1.1.4 Technical Condition of Specified Devices

The components to be supplied Ex Works, are equipped with hardware and software configurations, which meet the individual application requirements. Changes in hardware, software and firmware are permitted exclusively within the framework of the various alternatives that are documented in the specific manuals. WAGO Kontakttechnik GmbH & Co. KG will be exempted from any liability in case of changes in hardware or software as well as to non-compliant usage of components.

Please send your request for modified and new hardware or software configurations directly to WAGO Kontakttechnik GmbH & Co. KG.

1.2 Standards and Guidelines for Operating the 750 Series

Please adhere to the standards and guidelines required for the use of your system:

- The data and power lines shall be connected and installed in compliance with the standards required to avoid failures on your system and to substantially minimize any imminently hazardous situations resulting in personal injury.
- For assembly, start-up, maintenance and troubleshooting, adhere to the specific accident prevention provisions which apply to your system (e.g. BGV A 3, "Electrical Installations and Equipment").
- Emergency stop functions and equipment shall not be made ineffective. See relevant standards (e.g. DIN EN 418).
- The equipment of your system shall conform to EMC guidelines so that any electromagnetic interferences will be eliminated.
- Operating 750 Series components in home applications without further measures is permitted only if they meet the emission limits (emissions of interference) in compliance with EN 61000-6-3. You will find the detailed information in section "WAGO-I/O-SYSTEM 750" → "System Description" → "Technical Data".
- Please observe the safety precautions against electrostatic discharge in accordance with DIN EN 61340-5-1/-3. When handling the modules, please ensure that environmental factors (persons, working place and packaging) are well grounded.
- The valid standards and guidelines applicable for the installation of switch cabinets shall be adhered to.

1.3 Symbols



Danger

Always observe this information to protect persons from injury.



Warning

Always observe this information to prevent damage to the device.



Attention

Marginal conditions that must always be observed to ensure smooth and efficient operation.



ESD (Electrostatic Discharge)

Warning of damage to the components through electrostatic discharge. Observe the precautionary measure for handling components at risk of electrostatic discharge.



Note

Make important notes that are to be complied with so that a trouble-free and efficient device operation can be guaranteed.



Additional Information

References to additional literature, manuals, data sheets and internet pages.

1.4 Safety Information

When connecting the device to your installation and during operation, the following safety notes must be observed:



Danger

The WAGO-I/O-SYSTEM 750 and its components are an open system. It must only be assembled in housings, cabinets or in electrical operation rooms. Access is only permitted via a key or tool to authorized qualified personnel.



Danger

All power sources to the device must always be switched off before carrying out any installation, repair or maintenance work.



Warning

Replace defective or damaged device/module (e.g. in the event of deformed contacts), as the functionality of field bus station in question can no longer be ensured on a long-term basis.



Warning

The components are not resistant against materials having seeping and insulating properties. Belonging to this group of materials is: e.g. aerosols, silicones, triglycerides (found in some hand creams). If it cannot be ruled out that these materials appear in the component environment, then the components must be installed in an enclosure that is resistant against the above mentioned materials. Clean tools and materials are generally required to operate the device/module.



Warning

Soiled contacts must be cleaned using oil-free compressed air or with ethyl alcohol and leather cloths.



Warning

Do not use contact sprays, which could possibly impair the functioning of the contact area.



Warning

Avoid reverse polarity of data and power lines, as this may damage the devices.



ESD (Electrostatic Discharge)

The devices are equipped with electronic components that may be destroyed by electrostatic discharge when touched.



Warning

For components with ETHERNET/RJ-45 connectors:
Only for use in LAN, not for connection to telecommunication circuits.

1.5 Font Conventions

- italic* Names of paths and data files are marked in italic-type.
e.g.: *C:\Programs\WAGO-IO-CHECK*
- italic** Menu items are marked in italic-type, bold letters.
e.g.: ***Save***
- \ A backslash between two names characterizes the selection of a menu point from a menu.
e.g.: ***File | New***
- END** Pushbuttons are marked as bold with small capitals
e.g.: **ENTER**
- <>** Keys are marked bold within angle brackets
e.g.: **<F5>**
- Courier** The print font for program codes is Courier.
e.g.: **END_VAR**

1.6 Number Notation

Number code	Example	Note
Decimal	100	Normal notation
Hexadecimal	0x64	C notation
Binary	'100' '0110.0100'	In quotation marks, nibble separated with dots (.)

1.7 Scope

This manual describes the Digital Input Module 750-414
4 DI DC 5 V 0.2 ms, High-Side Switching of the modular WAGO-I/O-
SYSTEM 750.

Handling, assembly and start-up are described in the manual of the Fieldbus
Coupler. Therefore this documentation is valid only in the connection with the
appropriate manual.

2 I/O Modules

2.1 Digital Input Modules

2.1.1 750-414 [4 DI DC 5 V 0.2 ms, High-Side Switching]

4- Channel Digital Input Module DC 5 V,
2- or 3- conductor connection; high-side switching

2.1.1.1 View

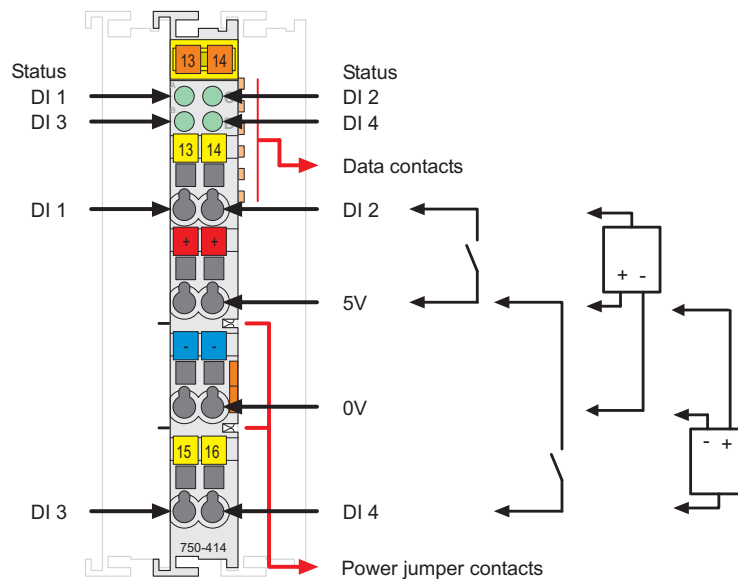

Fig. 2.1.1-1: View

g041400e

2.1.1.2 Description

The digital input module 750-414 receives control signals from digital field devices (sensors, switches, etc.).

The module is a 2- to 3-conductor device and has 4 input channels. Two sensors may be directly connected to the module.

As an example, two 3-conductor sensors can be directly connected using connection 5V, 0V and signal input DI1 or DI2. The connection of more sensors to signal inputs DI3 and DI4 requires a field side connection module (750-614) for 5V and for 0V, if need be.

Each input module has an RC noise rejection filter with a time constant of 0.2 ms.

The status of the input channels is indicated via status LEDs.

An optocoupler is used for electrical isolation between the bus and the field side.

Any configuration of the input modules is possible when designing the fieldbus node. Grouping of module types is not necessary.



Attention

An additional supply module must be added for the field supply with DC 5 V!

The supply voltage for the field side is made automatically through the individual I/O modules by means of power jumper contacts.



Warning

The maximum current of the internal power jumper contacts is 10 A. When configuring the system it is important not to exceed the maximum/sum current. However, if such a case should occur, another supply module must be added.

The digital input module 750-414 can be used with all couplers/controllers of the WAGO-I/O-SYSTEM 750.

2.1.1.3 Display Elements

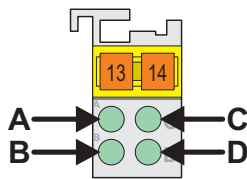

Fig. 2.1.1-2: Display Elements g041402x

LED	Channel	Designation	State	Function
A	1	Status DI 1	off	Input DI 1: Signal voltage (0)
			green	Input DI 1: Signal voltage (1)
C	2	Status DI 2	off	Input DI 2: Signal voltage (0)
			green	Input DI 2: Signal voltage (1)
B	3	Status DI 3	off	Input DI 3: Signal voltage (0)
			green	Input DI 3: Signal voltage (1)
D	4	Status DI 4	off	Input DI 4: Signal voltage (0)
			green	Input DI 4: Signal voltage (1)

2.1.1.4 Schematic Diagram

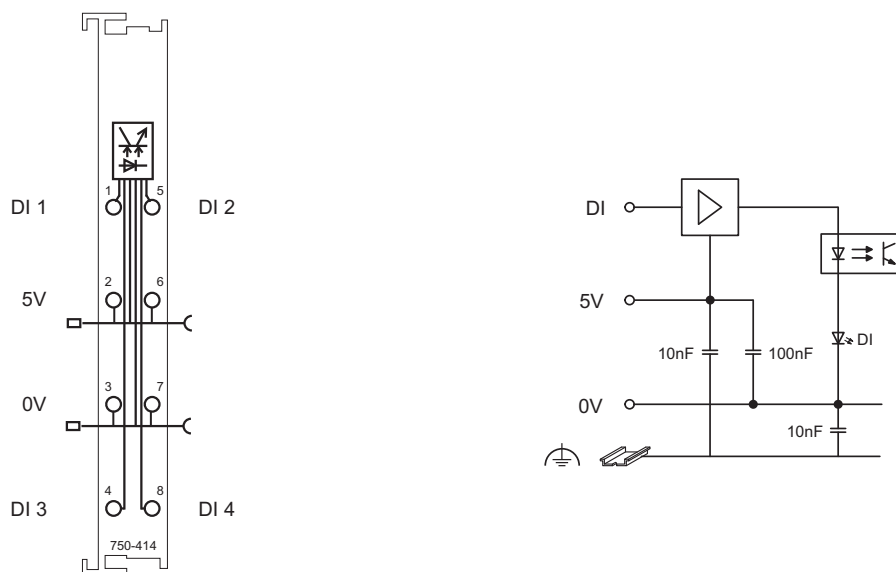





Fig. 2.1.1-3: Schematic Diagram

g041401e

2.1.1.5 Technical Data

Module Specific Data	
Number of inputs	4
Current consumption (internal)	5 mA
Nominal voltage	DC 5 V
Signal voltage (0)	DC 0 V to 0.8 V
Signal voltage (1)	DC 2.4 V to 5 V
Input filter	0.2 ms
Current supply <small>typ.</small>	50 μ A
Isolation	500 V (System/Field)
Internal bit width	4 Bit
Dimensions (mm) W x H x L	12 x 64* x 100 * from upper edge of 35 DIN rail
Weight	ca. 50 g
Standards and Regulations	
EMC-Immunity to interference (CE)	acc. to EN 61000-6-2: 2005
EMC-Emission of interference (CE)	acc. to EN 61000-6-4: 2007
ATEX guideline	Acc. to EN 60079-0:2006 and acc. to EN 60079-15:2005

Approvals		
	cUL _{US} (UL508)	
	cUL _{US} (ANSI/ISA 12.12.01)	Class I Div2 ABCD T4
	DEKRA	II 3 G Ex nA II T4
	Conformity Marking	



More Information

Detailed references to the approvals are listed in the document "Overview Approvals WAGO-I/O-SYSTEM 750", which you can find on the CD ROM ELECTRONICC Tools and Docs (Item-No.: 0888-0412)

or in the internet under:

www.wago.com → Documentation → WAGO-I/O-SYSTEM 750 → System Description

2.1.1.6 Process Image

Input bit	B3	B2	B1	B0
Meaning	Signal status DI 4 – Channel 4	Signal status DI 3 – Channel 3	Signal status DI 2 – Channel 2	Signal status DI 1 – Channel 1

3 Use in Hazardous Environments

The **WAGO-I/O-SYSTEM 750** (electrical equipment) is designed for use in Zone 2 hazardous areas.

The following sections include both the general identification of components (devices) and the installation regulations to be observed. The individual subsections of the "Installation Regulations" section must be taken into account if the I/O module has the required approval or is subject to the range of application of the ATEX directive.

3.1 Marking Configuration Examples

3.1.1 Marking for Europe according to CENELEC and IEC

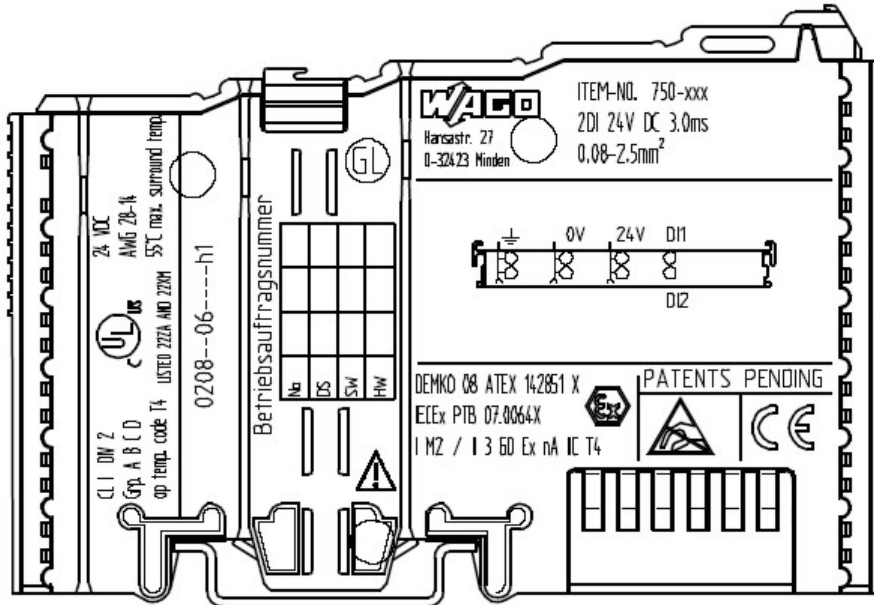

Figure 1: Side marking example for ATEX and IEC Ex approved I/O modules according to CENELEC and IEC

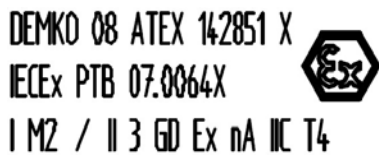

Figure 2: Printing Text detail – Marking example for ATEX and IEC Ex approved I/O modules according to CENELEC and IEC

Table 1: Description of marking example for ATEX and IEC Ex approved I/O modules according to CENELEC and IEC

Printing on Text	Description
DEMKO 08 ATEX 142851 X IECEX PTB 07.0064X	Approval body and/or number of the examination certificate
I M2 / II 3 GD	Explosion protection group and Unit category
Ex nA	Type of ignition and extended identification
IIC	Explosion protection group
T4	Temperature class

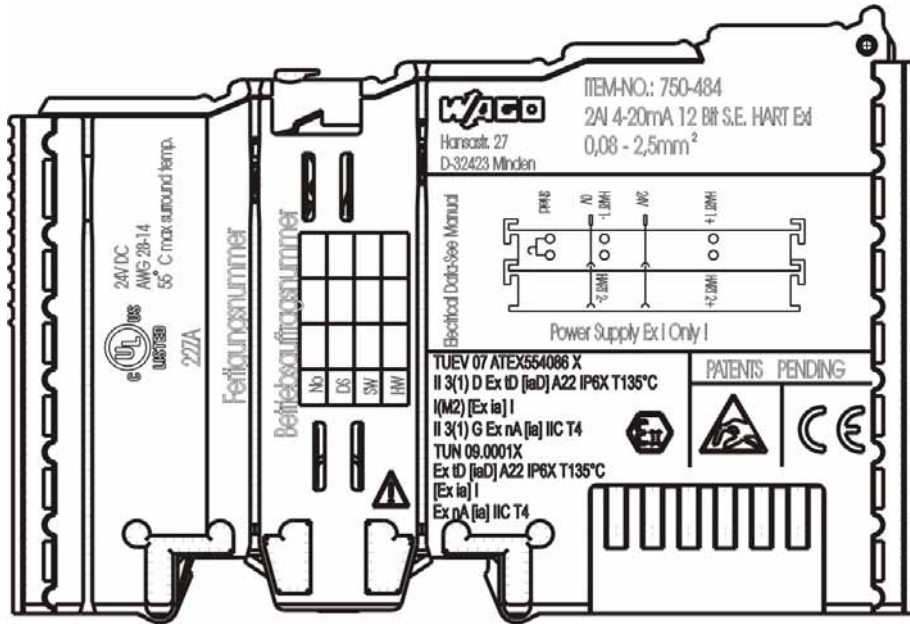

Figure 3: Side marking example for Ex i and IEC Ex i approved I/O modules according to CENELEC and IEC

TUEV 07 ATEX554086 X
II 3(1) D Ex tD [iaD] A22 IP6X T135°C
I(M2) [Ex ia] I
II 3(1) G Ex nA [ia] IIC T4
TUN 09.0001X
Ex tD [iaD] A22 IP6X T135°C
[Ex ia] I
Ex nA [ia] IIC T4



Figure 4: Text detail – Marking example for Ex i and IEC Ex i approved I/O modules according to CENELEC and IEC

Table 2: Description of marking example for Ex i and IEC Ex i approved I/O modules according to CENELEC and IEC

Inscription text	Description
TÜV 07 ATEX 554086 X TUN 09.0001X	Approving authority or certificate numbers
Dust	
II	Device group: All except mining
3(1)D	Device category: Zone 22 device (Zone 20 subunit)
Ex	Explosion protection mark
tD	Protection by enclosure
[iaD]	Approved in accordance with "Dust intrinsic safety" standard
A22	Surface temperature determined according to Procedure A, use in Zone 22
IP6X	Dust-tight (totally protected against dust)
T 135°C	Max. surface temp. of the enclosure (no dust bin)
Mining	
I	Device group: Mining
(M2)	Device category: High degree of safety
[Ex ia]	Explosion protection: Mark with category of type of protection intrinsic safety: Even safe when two errors occur
I	Device group: Mining
Gases	
II	Device group: All except mining
3(1)G	Device category: Zone 2 device (Zone 0 subunit)
Ex	Explosion protection mark
nA	Type of protection: Non-sparking operating equipment
[ia]	Category of type of protection intrinsic safety: Even safe when two errors occur
IIC	Explosion Group
T4	Temperature class: Max. surface temperature 135°C

3.1.2 Marking for America according to NEC 500

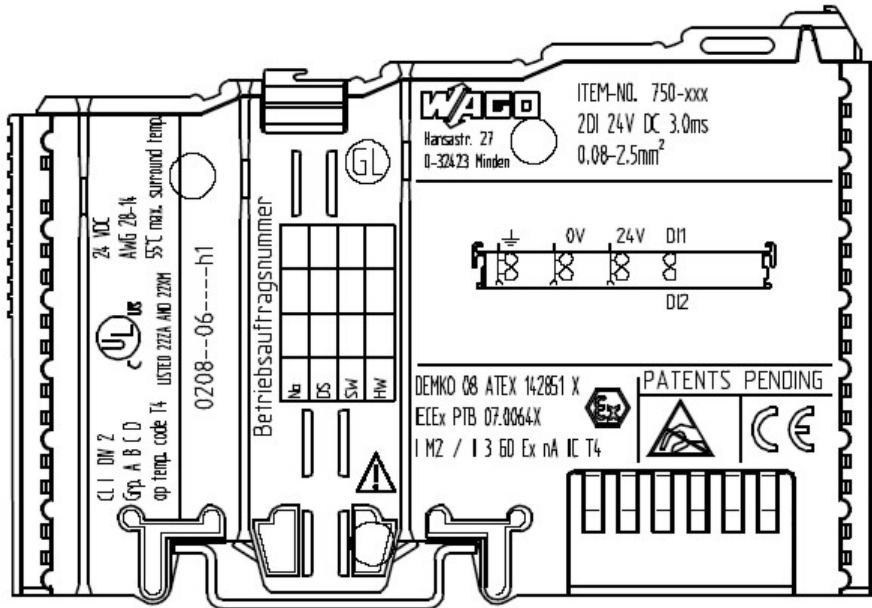

Figure 5: Side marking example for I/O modules according to NEC 500



Figure 6: Text detail – Marking example for I/O modules according to NEC 500

Table 3: Description of marking example for I/O modules according to NEC 500

Printing on Text	Description
CL 1	Explosion protection group (condition of use category)
DIV 2	Area of application (zone)
Grp. ABCD	Explosion group (gas group)
Optemp code T4	Temperature class

3.2 Installation Regulations

In the **Federal Republic of Germany**, various national regulations for the installation in explosive areas must be taken into consideration. The basis for this forms the working reliability regulation, which is the national conversion of the European guideline 99/92/E6. They are complemented by the installation regulation EN 60079-14. The following are excerpts from additional VDE regulations:

Table 4: VDE Installation Regulations in Germany

DIN VDE 0100	Installation in power plants with rated voltages up to 1000 V
DIN VDE 0101	Installation in power plants with rated voltages above 1 kV
DIN VDE 0800	Installation and operation in telecommunication plants including information processing equipment
DIN VDE 0185	lightning protection systems

The **USA** and **Canada** have their own regulations. The following are excerpts from these regulations:

Table 5: Installation Regulations in USA and Canada

NFPA 70	National Electrical Code Art. 500 Hazardous Locations
ANSI/ISA-RP 12.6-1987	Recommended Practice
C22.1	Canadian Electrical Code

NOTICE

Notice the following points

When using the **WAGO-I/O SYSTEM 750** (electrical operation) with Ex approval, the following points are mandatory:

3.2.1 Special Conditions for Safe Operation of the ATEX and IEC Ex (acc. DEMKO 08 ATEX 142851X and IECEx PTB 07.0064)

The fieldbus-independent I/O modules of the WAGO-I/O-SYSTEM 750-.../...-... must be installed in an environment with degree of pollution 2 or better. In the final application, the I/O modules must be mounted in an enclosure with IP 54 degree of protection at a minimum with the following exceptions:

- I/O modules 750-440, 750-609 and 750-611 must be installed in an IP 64 minimum enclosure.
- I/O module 750-540 must be installed in an IP 64 minimum enclosure for 230 V AC applications.
- I/O module 750-440 may be used up to max. 120 V AC.

When used in the presence of combustible dust, all devices and the enclosure shall be fully tested and assessed in compliance with the requirements of IEC 61241-0:2004 and IEC 61241-1:2004.

When used in mining applications the equipment shall be installed in a suitable enclosure according to EN 60079-0:2006 and EN 60079-1:2007.

I/O modules fieldbus plugs or fuses may only be installed, added, removed or replaced when the system and field supply is switched off or the area exhibits no explosive atmosphere.

DIP switches, coding switches and potentiometers that are connected to the I/O module may only be operated if an explosive atmosphere can be ruled out.

I/O module 750-642 may only be used in conjunction with antenna 758-910 with a max. cable length of 2.5 m.

To exceed the rated voltage no more than 40%, the supply connections must have transient protection.

The permissible ambient temperature range is 0 °C to +55 °C.

3.2.2 Special conditions for safe use (ATEX Certificate TÜV 07 ATEX 554086 X)

1. For use as Gc- or Dc-apparatus (in zone 2 or 22) the field bus independent I/O modules WAGO-I/O-SYSTEM 750-*** shall be erected in an enclosure that fulfils the requirements of the applicable standards (see the marking) EN 60079-0, EN 60079-11, EN 60079-15, EN 61241-0 and EN 61241-1. For use as group I, electrical apparatus M2, the apparatus shall be erected in an enclosure that ensures a sufficient protection according to EN 60079-0 and EN 60079-1 and the degree of protection IP64. The compliance of these requirements and the correct installation into an enclosure or a control cabinet of the devices shall be certified by an ExNB.
2. If the interface circuits are operated without the field bus coupler station type 750-3../...-... (DEMKO 08 ATEX 142851 X), measures must be taken outside of the device so that the rating voltage is not being exceeded of more than 40% because of transient disturbances.
3. DIP-switches, binary-switches and potentiometers, connected to the module may only be actuated when explosive atmosphere can be excluded.
4. The connecting and disconnecting of the non-intrinsically safe circuits is only permitted during installation, for maintenance or for repair purposes. The temporal coincidence of explosion hazardous atmosphere and installation, maintenance resp. repair purposes shall be excluded.
5. For the types 750-606, 750-625/000-001, 750-487/003-000, 750-484 the following shall be considered: The interface circuits shall be limited to overvoltage category I/II/III (non mains/mains circuits) as defined in IEC 60664-1.
6. For the type 750-601 the following shall be considered: Do not remove or replace the fuse when the apparatus is energized.
7. The ambient temperature range is: $0^{\circ}\text{C} \leq T_a \leq +55^{\circ}\text{C}$ (for extended details please note certificate).

-
8. The following warnings shall be placed nearby the unit:

 **WARNING**

Do not remove or replace fuse when energized!

If the module is energized do not remove or replace the fuse.

 **WARNING**

Do not separate when energized!

Do not separate the module when energized!

 **WARNING**

Separate only in a non-hazardous area!

Separate the module only in a non-hazardous area!

3.2.3 Special conditions for safe use (IEC-Ex Certificate TUN 09.0001 X)

1. For use as Dc- or Gc-apparatus (in zone 2 or 22) the fieldbus independent I/O modules WAGO-I/O-SYSTEM 750-*** shall be erected in an enclosure that fulfils the requirements of the applicable standards (see the marking) IEC 60079-0, IEC 60079-11, IEC 60079-15, IEC 61241-0 and IEC 61241-1. For use as group I, electrical apparatus M2, the apparatus shall be erected in an enclosure that ensures a sufficient protection according to IEC 60079-0 and IEC 60079-1 and the degree of protection IP64. The compliance of these requirements and the correct installation into an enclosure or a control cabinet of the devices shall be certified by an ExCB.
2. Measures have to be taken outside of the device that the rating voltage is not being exceeded of more than 40% because of transient disturbances.
3. DIP-switches, binary-switches and potentiometers, connected to the module may only be actuated when explosive atmosphere can be excluded.
4. The connecting and disconnecting of the non-intrinsically safe circuits is only permitted during installation, for maintenance or for repair purposes. The temporal coincidence of explosion hazardous atmosphere and installation, maintenance resp. repair purposes shall be excluded.
5. For the types 750-606, 750-625/000-001, 750-487/003-000, 750-484 the following shall be considered: The interface circuits shall be limited to overvoltage category I/II/III (non mains/mains circuits) as defined in IEC 60664-1.
6. For the type 750-601 the following shall be considered: Do not remove or replace the fuse when the apparatus is energized.
7. The ambient temperature range is: $0^{\circ}\text{C} \leq T_a \leq +55^{\circ}\text{C}$ (for extended details please note certificate).

-
8. The following warnings shall be placed nearby the unit:

 **WARNING**

Do not remove or replace fuse when energized!

If the module is energized do not remove or replace the fuse.

 **WARNING**

Do not separate when energized!

Do not separate the module when energized!

 **WARNING**

Separate only in a non-hazardous area!

Separate the module only in a non-hazardous area!

3.2.4 Special conditions for safe use (ATEX Certificate DEKRA 11ATEX0203 X)

1. The components shall be installed in a suitable enclosure providing a degree of protection of at least IP54 according to EN 60529, taking into account the environmental conditions under which the equipment will be used.
2. When the temperature under rated conditions exceeds 70 °C at the cable or conduit entry point, or 80 °C at the branching point of the conductors, the temperature specification of the selected cable shall be in compliance with the actual measured temperature values.
3. Provisions shall be made to prevent the rated voltages from being exceeded by transient disturbances of more than 40 %.
4. Components may only be removed or inserted when the system supply and the field supply are switched off, or when the location is known to be non-hazardous.
5. Fieldbus connectors may only be disconnected or connected when the system supply is switched off, or when the location is known to be non-hazardous.
6. The fuses, present in de the system modules 750-6xx may only be replaced when the supply is switched off, or when the location is known to be non-hazardous.
7. Address selectors and ID switches may only be adjusted when the system supply is switched off, or when the location is known to be non-hazardous.
8. The ambient temperature range is: $0^{\circ}\text{C} \leq T_a \leq +55^{\circ}\text{C}$.

3.2.5 ANSI/ISA 12.12.01

This equipment is suitable for use in Class I, Division 2, Groups A, B, C, D or non-hazardous locations only.

This equipment is to be fitted within tool-secured enclosures only.

WARNING

Explosion hazard!

Explosion hazard - substitution of components may impair suitability for Class I, Div. 2.

WARNING

Disconnect device when power is off and only in a non-hazardous area!

Do not disconnect equipment unless power has been switched off or the area is known to be non-hazardous near each operator accessible connector and fuse holder." When a fuse is provided, the following information shall be provided: "A switch suitable for the location where the equipment is installed shall be provided to remove the power from the fuse."

For devices with Ethernet connectors:

"Only for use in LAN, not for connection to telecommunication circuits".

WARNING

Use only with antenna module 758-910!

Use Module 750-642 only with antenna module 758-910.

For Couplers/Controllers and Economy bus modules only: "The configuration Interface Service connector is for temporary connection only. Do not connect or disconnect unless the area is known to be nonhazardous. Connection or disconnection in an explosive atmosphere could result in an explosion.

WARNING

Devices containing fuses must not be fitted into circuits subject to over loads!

Devices containing fuses must not be fitted into circuits subject to over loads, e.g. motor circuits!

 **WARNING**

Do not connect or disconnect SD-Card unless the area known to be free of ignitable concentrations of flammable gases or vapors!

Do not connect or disconnect SD-Card while circuit is live unless the area is known to be free of ignitable concentrations of flammable gases or vapors.



Information

Additional Information

Proof of certification is available on request. Also take note of the information given on the module technical information sheet. The Instruction Manual, containing these special conditions for safe use, must be readily available to the user.



WAGO Kontakttechnik GmbH & Co. KG
Postfach 2880 • D-32385 Minden
Hansastraße 27 • D-32423 Minden
Phone: 05 71/8 87 – 0
Fax: 05 71/8 87 – 1 69
E-Mail: info@wago.com

Internet: <http://www.wago.com>
