

WAGO → I/O → SYSTEM 750

**Fieldbus Independent
I/O Modules**

**2AI/2DO VIB VRMS/SPM Multi
750-645**



Manual

Version 1.2.0

Copyright © 2008 by WAGO Kontakttechnik GmbH & Co. KG
All rights reserved.

WAGO Kontakttechnik GmbH & Co. KG

Hansastraße 27
D-32423 Minden

Phone: +49 (0) 571/8 87 – 0
Fax: +49 (0) 571/8 87 – 1 69
E-Mail: info@wago.com
Web: <http://www.wago.com>

Technical Support

Phone: +49 (0) 571/8 87 – 5 55
Fax: +49 (0) 571/8 87 – 85 55
E-Mail: support@wago.com

Every conceivable measure has been taken to ensure the correctness and completeness of this documentation. However, as errors can never be fully excluded, we would appreciate any information or ideas at any time.

E-Mail: documentation@wago.com

We wish to point out that the software and hardware terms as well as the trademarks of companies used and/or mentioned in the present manual are generally trademark or patent protected.

Content

1 Important Notes	5
1.1 Legal Principles	5
1.1.1 Copyright	5
1.1.2 Personnel Qualification	5
1.1.3 Conforming Use of Series 750	6
1.1.4 Technical Condition of the Devices	6
1.2 Standards and Regulations for Operating the 750 Series	7
1.3 Symbols	8
1.4 Safety Information	9
1.5 Font Conventions	10
1.6 Number Notation	10
1.7 Scope	10
2 Condition Monitoring	11
2.1 Tasks and Options	11
2.2 Machine Condition Monitoring with VIB-I/O Modules	11
2.2.1 Fundamentals	11
2.2.1.1 Vibration Severity	11
2.2.1.2 ISO 10816-3	11
2.2.2 Roller Bearing Analysis	13
2.2.3 Shock Impulses	13
2.2.3.1 Measuring Shock Impulses	13
2.2.3.2 Shock Impulse Evaluation	14
2.2.3.3 The Shock Impulse Carpet Value	14
2.2.3.4 The Shock Impulse Peak Value	15
2.2.4 Damage History	16
2.2.4.1 Three Stages to Evaluate a Roller Bearing State	16
2.2.4.2 The Evaluation Scale	17
2.2.4.2.1 Good Operating Condition	17
2.2.4.2.2 Limited Operating Condition	17
2.2.4.2.3 Poor Operating Condition	18
2.2.5 Typical Shock Impulse Diagrams	19
2.2.5.1 Bearing in Good Condition	19
2.2.5.2 Bearing Damage of Foreign Matter in the Lubricant	19
2.2.5.3 Installation Errors or Insufficient Lubrication	20
2.2.5.4 Dry-Run or Cavitation	20
2.2.6 The Measuring Point	21
3 Overview Condition Monitoring Components 750-645, 750-925	24
4 I/O Modules	25
4.1 Special Modules	25
4.1.1 750-645 [2AI/2DO VIB VRMS/SPM Multi]	25
4.1.1.1 View	25
4.1.1.2 Description	25
4.1.1.3 Display Elements	28

4.1.1.4	Schematic Wiring Diagram.....	29
4.1.1.5	Technical Data	30
4.1.1.6	Function Description.....	32
4.1.1.6.1	Operating Mode.....	33
4.1.1.6.1.1	Messablauf im Einkanal-Betrieb	33
4.1.1.6.1.2	Messablauf im Zweikanal-Betrieb	33
4.1.1.6.2	Parameter Vibration Monitoring (RMS).....	35
4.1.1.6.3	Parameter Roller Bearing Monitoring (SPM)	35
4.1.1.7	Process Image	36
4.1.1.7.1	Overview	36
4.1.1.7.2	Control and Status Byte in Process Data Communication.....	37
4.1.1.8	Setting the 750-645 Module Using Register Communication.....	42
4.1.1.8.1	Control- and Status Byte at Register Communication	44
4.1.1.9	Setting the 750-645 Module with WAGO-I/O-CHECK 2.....	46
5	Accessories	49
5.1	Sensors.....	49
5.1.1	750-925 [Tandem-Piezo® Acceleration Sensor].....	49
5.1.1.1	View	49
5.1.1.2	Description.....	49
5.1.1.3	Technical Data	50
5.1.1.4	Screwed Adapter with M8 Thread.....	52
5.1.1.5	Electrical Connection.....	54
5.1.1.6	Measurement Report Template.....	55
6	Use in Hazardous Environments	57
6.1	Marking Configuration Examples	58
6.1.1	Marking for Europe according to CENELEC and IEC	58
6.1.2	Marking for America according to NEC 500	61
6.2	Installation Regulations.....	62
6.2.1	Special Conditions for Safe Operation of the ATEX and IEC Ex (acc. DEMKO 08 ATEX 142851X and IECEx PTB 07.0064).....	63
6.2.2	Special conditions for safe use (ATEX Certificate TÜV 07 ATEX 554086 X)	64
6.2.3	Special conditions for safe use (IEC-Ex Certificate TUN 09.0001 X).....	66
6.2.4	ANSI/ISA 12.12.01	68

1 Important Notes

This section provides only a summary of the most important safety requirements and notes which will be mentioned in the individual sections. To protect your health and prevent damage to the devices, it is essential to read and carefully follow the safety guidelines.

1.1 Legal Principles

1.1.1 Copyright

This manual including all figures and illustrations contained therein is subject to copyright. Any use of this manual which infringes the copyright provisions stipulated herein, is not permitted. Reproduction, translation and electronic and phototechnical archiving and amendments require the written consent of WAGO Kontakttechnik GmbH & Co. KG, Minden. Non-observance will entail the right of claims for damages.

WAGO Kontakttechnik GmbH & Co. KG reserves the right of changes serving technical progress.

All rights developing from the issue of a patent or the legal protection of utility patents are reserved to WAGO Kontakttechnik GmbH & Co. KG.

Third-party products are always indicated without any notes concerning patent rights. Thus, the existence of such rights must not be excluded.

1.1.2 Personnel Qualification

The use of the product described in this manual requires special qualifications, as shown in the following table:

Activity	Electrical specialist	Instructed personnel*)	Specialists**) having qualifications in PLC programming
Assembly	X	X	
Commissioning	X		X
Programming			X
Maintenance	X	X	
Troubleshooting	X		
Disassembly	X	X	

*) Instructed persons have been trained by qualified personnel or electrical specialists.

**) A specialist is someone who, through technical training, knowledge and experience, demonstrates the ability to meet the relevant specifications and identify potential dangers in the mentioned field of activity.

All personnel must be familiar with the applicable standards.
WAGO Kontakttechnik GmbH & Co. KG declines any liability resulting from improper action and damage to WAGO products and third party products due to non-observance of the information contained in this manual.

1.1.3 Conforming Use of Series 750

The couplers and controllers of the modular I/O System 750 receive digital and analog signals from the I/O modules and sensors and transmit them to the actuators or higher level control systems. Using the WAGO controllers, the signals can also be (pre-)processed.

The device is designed for IP20 protection class. It is protected against finger touch and solid impurities up to 12.5mm diameter, but not against water penetration. Unless otherwise specified, the device must not be operated in wet and dusty environments.

1.1.4 Technical Condition of the Devices

For each individual application, the components are supplied from the factory with a dedicated hardware and software configuration. Changes in hardware, software and firmware are only admitted within the framework of the possibilities documented in the manuals. All changes to the hardware or software and the non-conforming use of the components entail the exclusion of liability on the part of WAGO Kontakttechnik GmbH & Co. KG. Please direct any requirements pertaining to a modified and/or new hardware or software configuration directly to WAGO Kontakttechnik GmbH & Co. KG.

1.2 Standards and Regulations for Operating the 750 Series

Please observe the standards and regulations that are relevant to your installation:

- The data and power lines must be connected and installed in compliance with the standards to avoid failures on your installation and eliminate any danger to personnel.
- For installation, startup, maintenance and repair, please observe the accident prevention regulations of your machine (e.g. BGV A 3, "Electrical Installations and Equipment").
- Emergency stop functions and equipment must not be made ineffective. See relevant standards (e.g. DIN EN 418).
- Your installation must be equipped in accordance to the EMC guidelines so that electromagnetic interferences can be eliminated.
- Operating 750 Series components in home applications without further measures is only permitted if they meet the emission limits (emissions of interference) according to EN 61000-6-3. You will find the relevant information in the section on "WAGO-I/O-SYSTEM 750" → "System Description" → "Technical Data".
- Please observe the safety measures against electrostatic discharge according to DIN EN 61340-5-1/-3. When handling the modules, ensure that the environment (persons, workplace and packing) is well grounded.
- The relevant valid and applicable standards and guidelines concerning the installation of switch cabinets are to be observed.

1.3 Symbols



Danger

Always observe this information to protect persons from injury.



Warning

Always observe this information to prevent damage to the device.



Attention

Marginal conditions that must always be observed to ensure smooth and efficient operation.



ESD (Electrostatic Discharge)

Warning of damage to the components through electrostatic discharge. Observe the precautionary measure for handling components at risk of electrostatic discharge.



Note

Make important notes that are to be complied with so that a trouble-free and efficient device operation can be guaranteed.



Additional Information

References to additional literature, manuals, data sheets and internet pages.

1.4 Safety Information

When connecting the device to your installation and during operation, the following safety notes must be observed:



Danger

The WAGO-I/O-SYSTEM 750 and its components are an open system. It must only be assembled in housings, cabinets or in electrical operation rooms. Access is only permitted via a key or tool to authorized qualified personnel.



Danger

All power sources to the device must always be switched off before carrying out any installation, repair or maintenance work.



Warning

Replace defective or damaged device/module (e.g. in the event of deformed contacts), as the functionality of field bus station in question can no longer be ensured on a long-term basis.



Warning

The components are not resistant against materials having seeping and insulating properties. Belonging to this group of materials is: e.g. aerosols, silicones, triglycerides (found in some hand creams). If it cannot be ruled out that these materials appear in the component environment, then the components must be installed in an enclosure that is resistant against the above mentioned materials. Clean tools and materials are generally required to operate the device/module.



Warning

Soiled contacts must be cleaned using oil-free compressed air or with ethyl alcohol and leather cloths.



Warning

Do not use contact sprays, which could possibly impair the functioning of the contact area.



Warning

Avoid reverse polarity of data and power lines, as this may damage the devices.



ESD (Electrostatic Discharge)

The devices are equipped with electronic components that may be destroyed by electrostatic discharge when touched.



Warning

For components with Ethernet/RJ45 connectors:
Only for use in LAN, not for connection to telecommunication circuits

1.5 Font Conventions

<i>italic</i>	Names of paths and files are marked in italic. e.g.: <i>C:\Programs\WAGO-IO-CHECK</i>
<i>italic</i>	Menu items are marked in bold italic. e.g.: <i>Save</i>
\	A backslash between two names characterizes the selection of a menu point from a menu. e.g.: <i>File New</i>
END	Press buttons are marked as bold with small capitals e.g.: ENTER
< >	Keys are marked bold within angle brackets e.g.: <F5>
Courier	The print font for program codes is Courier. e.g.: END_VAR

1.6 Number Notation

Number code	Example	Note
Decimal	100	Normal notation
Hexadecimal	0x64	C notation
Binary	'100' '0110.0100'	Within inverted commas, Nibble separated with dots

1.7 Scope

This manual describes the Special Module 750-645
2AI/2DO VIB VRMS/SPM Multi of the modular WAGO-I/O-SYSTEM 750.

Handling, assembly and start-up are described in the manual of the Fieldbus Coupler. Therefore this documentation is valid only in the connection with the appropriate manual.

2 Condition Monitoring

2.1 Tasks and Options

The growing cost pressure within the global competition increasingly forces companies to maximize existing saving potentials and to implement measures for more efficiency. In the maintenance sector this means the assurance of a fault free production process, the avoidance of unscheduled machine downtime and the optimum exploitation of the installation lifespan.

For the realization of these goals, online condition monitoring systems are of paramount importance. Faults can be diagnosed early, maintenance measures scheduled for the optimum timelines and unexpected operational shuts-downs can be avoided.

The continuous registration of the machine health condition via the fieldbus permits an early analysis and reaction prior to the actual occurrence of damages.

For this purpose, WAGO offers the WAGO-I/O-SYSTEM function modules for recording and processing of the relevant parameters, such as current, temperature, standard signals and machine vibrations.

Typical applications will be all standard machines, such as electric motors, ventilators, pumps, air conditioners, etc.

2.2 Machine Condition Monitoring with VIB-I/O Modules

2.2.1 Fundamentals

2.2.1.1 Vibration Severity

The vibration severity is defined as the largest effective value of the vibration speed occurring at functionally important locations, in a frequency range of 2 or 10 to 1000 Hz. The vibration severity is an energetic mean value of all vibration components within a wide and comparatively low frequency range. The vibration severity is relative to the energy level of the machine vibration and thus a suitable indicator for the vibration forces acting on a machine.

2.2.1.2 ISO 10816-3

The following illustration shows the criteria for an analysis of the vibration severity values. The classification depends on the capacity and installation of the machine.

The frequency range to be recorded is to be selected according to the machine RPM (10 Hz to 1000 Hz for > 600 RPM, 2 Hz to 1000 Hz for > 120 RPM).

- Group 1: large machines; 300 kW to 50 MW capacity

- Group 2: medium machines; 15 kW to 300 kW capacity
- Group 3: pumps, indirect drive
- Group 4: pumps, direct drive

									Vibration Velocity (RMS) (10 - 1000 Hz, r > 600 1/min) (2 - 1000 Hz, r > 120 1/min) mm/s	
				D						11
										7.1
										4.5
				C						3.5
										2.8
				B						2.3
										1.4
				A						0.71
rigid	soft	rigid	soft	rigid	soft	rigid	soft	Machine Base		
Pumps radial, axial, diagonal P > 15 KW				medium-size Machines 15 KW < P < 300 KW		large-size Machines 300 KW < P < 50 MW		Machine Type		
Direct Drive		Intermediate Shaft / Belt Drive		Motors 160 mm < H < 315 mm		Motors 315 mm < H				
Group 4		Group 3		Group 2		Group 1		Group		

Fig. 2.2.1-1: Scaling system ISO 10816-3

g064530e

- A: newly commissioned
- B: unlimited long-term operation admissible
- C: short-term operation admissible
- D: vibration causes damages

The machine condition is determined by searching for the measured vibration speed in the right column and reading the corresponding machine class at the lower axis.

Derived measures

- A, B: Continuous measuring in regular time intervals.
- C: Determination of the cause of vibration and exact observation of the machine. Plan for shut-down.
- D: Immediate measures are required: localization of the cause, machine shut-down and problem correction.

2.2.2 Roller Bearing Analysis

The VIB-I/O module uses the shock pulse method to analyze the roller bearing. This method provides the measurement of mechanical shock impulses. They arise during operation from the contact between the roller bearings and the rolling path in the load zone and spread in waves in the material. The signals measured during the rolling process divide in the carpet value and the peak value. With increasing deterioration of the measuring state, the distance between those two values will increase. The VIB-I/O module measures the carpet value, as well as the peak value. With the analysis of these two parameters, damages can be detected very early. Shock impulses are influenced by the rolling speed of the roller bearings.

The subsequently used scale in three parts for the evaluation of the roller bearing state ('good', 'limited' and 'poor') shall serve only as a pictorial example. The actual limits boundaries between 'good', 'limited' and 'poor' roller bearing condition can differ strongly from bearing to bearing, depending on the design and operational conditions. A reliable diagnosis of a bearing condition is only possible with a trend analysis over longer periods of time.

2.2.3 Shock Impulses

Shock impulses are momentary impulses arising from mechanical damages to roller bearings or the bearing surfaces. The severity of these shock impulses depends, amongst others, from the rolling speed of the roller bearings. Shock impulses occur during machine operation as frequently as vibrations. They can be traced to various causes, e.g., shocks due to harsh handling or explosions. The deciding factor is their short duration. A shock impulse may be defined, as e.g., transmission of kinetic energy to a system in a relative short time.

Shock impulses occur in bearings. There, they are caused by the contact between the roller bearings and the rolling path of the load zone. Because both, the surface of the rolling path and the surface of the roller bearing are rough, signals are generated by the collision at locations where the lubricant layer is not thick enough and these roughness peaks meet. These signals spread in waves and are transmitted to all other surrounding parts via the bearing.

2.2.3.1 Measuring Shock Impulses

The acceleration sensor mounted to the load zone of the bearing is actuated through shock impulses at its natural resonance of approx. 30 kHz. A high band filter is used to suppress low frequency portions, - such as those caused by alignment or balancing errors. The remaining signal portions are processed by the computer to obtain various shock impulse parameters that are described in the following pages.

2.2.3.2 Shock Impulse Evaluation

The following scale for the evaluation of shock impulses has been created. The measured shock impulses are classified here in the categories of the bearing state, from 'good', to 'limited' and finally to 'poor'.

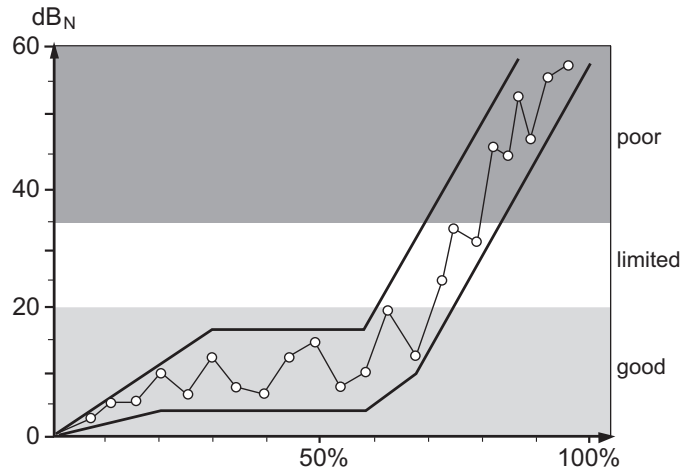

Fig. 2.2.3-1: Evaluation of shock impulses

g064510e

The illustration shows the progress of a trend measurement from originally good values to poor values (bearing damage).

This provides a quick and clear overview of the evaluation of the measurement results, without complex terminology or calculation.



Note

Because roughness is rolled into the surface during operation, but new damages also occur, the measured values may strongly rise or decline for short periods of time. For this reason, the "snapshot" of a measured value is less representative than a trend measurement and trend monitoring over a longer period of time.

2.2.3.3 The Shock Impulse Carpet Value

Roughness in the surface can cause a quick sequence of low shock impulses, together creating the carpet value of a bearing. This is the basic noise which is audible through a screwdriver pressed to the bearing. The carpet value is measured in decibel (dBc = decibel carpet value). The carpet value (■) provides information to the lubrication of a bearing, the assembly condition and the different load of a bearing (e.g. due to alignment errors). The carpet value directly corresponds to the lubricant thickness between roller bearings and rolling path. If the rolling path and roller bearings are separated by a complete and sufficient lubrication layer, the carpet value is low. This is shown in the following diagram.

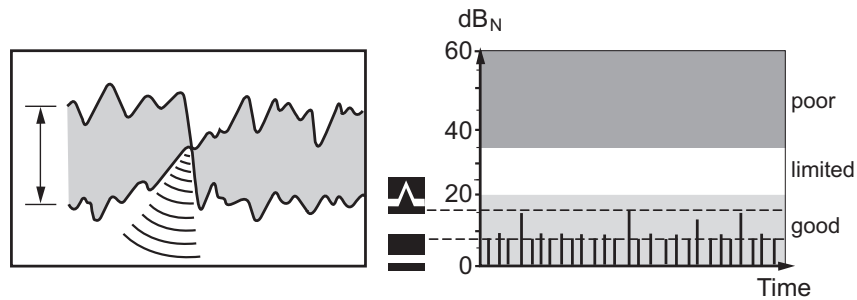

Fig. 2.2.3-2: Low carpet value

g064518e

The carpet value rises when the lubrication layer decreases and rolling path and roller bearing touch at more and more locations. The following diagram shows an increased carpet value.

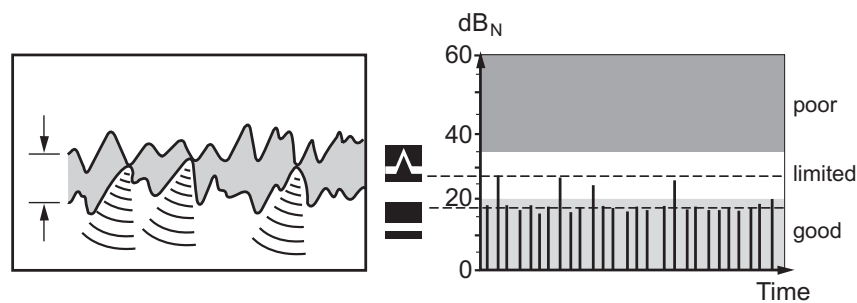

Fig.. 2.2.3-3: Increased carpet value

g064519e

The carpet value helps to pinpoint the cause for limited or poor operating conditions.

2.2.3.4 The Shock Impulse Peak Value

Bearing damages (i.e., relatively large roughness of the surfaces) result in individual, very high shock impulses (see illustration below). In some cases, this can be heard through a screwdriver pressed to the bearing. The highest shock impulse values measured at a bearing are called peak value (or maximum value) and are shown in dB_M (decibel maximum value). The peak value (▲) provides information to the operating conditions of a bearing and already existing bearing damages. The following diagram shows shock impulses indicating a bearing damage.

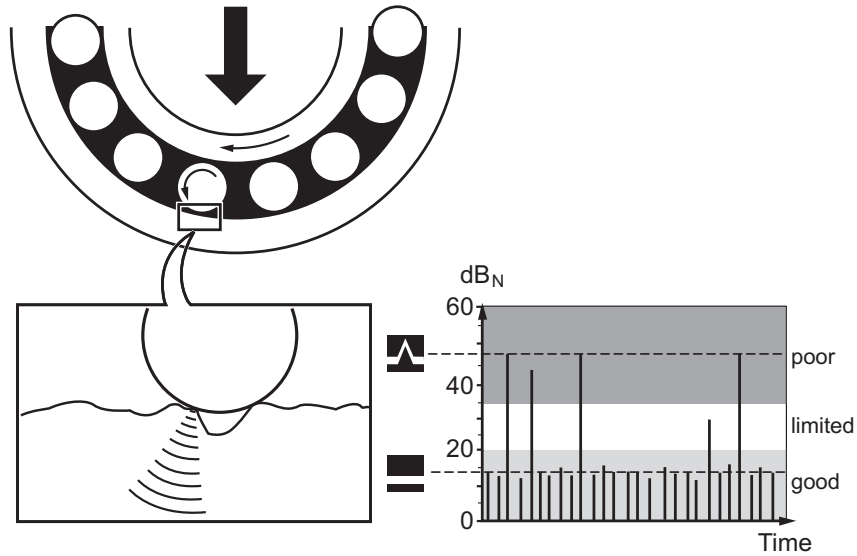

Fig. 2.2.3-4: Shock impulses at bearing damage

g064520e

2.2.4 Damage History

2.2.4.1 Three Stages to Evaluate a Roller Bearing State

By performing continuous shock impulse measurements, changes in the bearing condition can be easily detected. The operating time starts at 0 % with the installation of the bearing and ends with the bearing damage at 100 %. The diagram below shows the shock impulse values (only peak values) of a normal roller bearing. 'Normal' means here that the installation and lubrication are proper and that the bearing is under constantly distributed load. The continuous increase of the shock impulse values can be traced to material fatigue and consequential bearing damage.

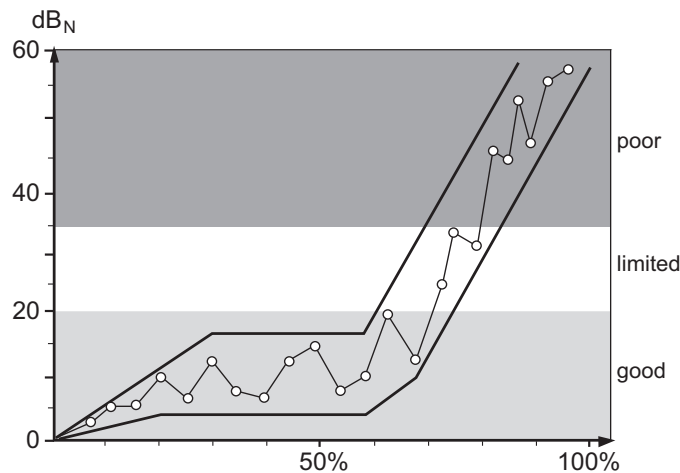

Fig. 2.2.4-1: Lifespan curve

g064510e

Low deviations of the measured values are quite normal. They can be caused by temperature changes, changes in bearing load, the time passed since the last lubrication and other influences during operation.

Deciding factor for the planning of bearing changes is the trend measurement and change analysis.

Continuous shock impulse measurements clearly show changes in the bearing condition during operation.



Note

New bearings may require a break-in time, during which the base noise is decreasing.

2.2.4.2 The Evaluation Scale

The roller bearing evaluation scale is divided in three stages:

1. Good operating condition
2. Limited operating condition
3. Poor operating condition

The subsequent diagrams show how carpet value and peak value can develop.

2.2.4.2.1 Good Operating Condition

The diagram below shows a bearing in a good operating condition. The low carpet value indicates that the installation, lubrication and load are normal. A peak value that is only little higher than the carpet value confirms this evaluation.

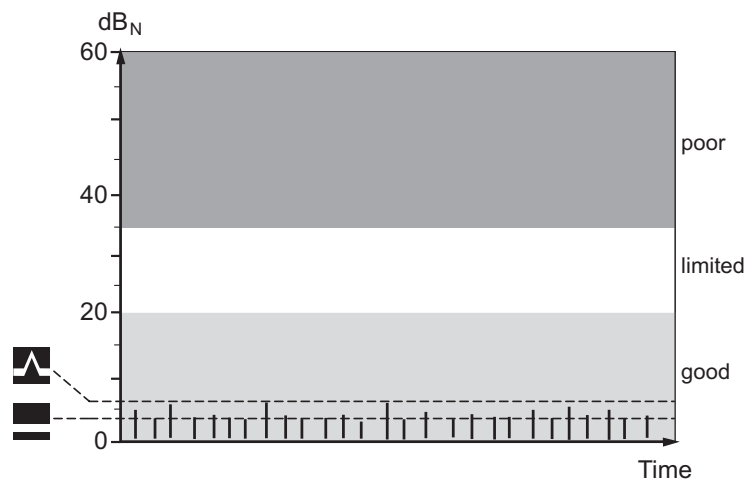

Fig. 2.2.4-2: Good operating condition

g064511e

A low carpet value indicates that the installation, lubrication and load are normal.

2.2.4.2.2 Limited Operating Condition

A significant increase of both values is a first warning signal. A bearing damage in the making only appears during limited operating condition. The

peak value reaches increased values and the difference between peak values and carpet value rises (see diagram below).

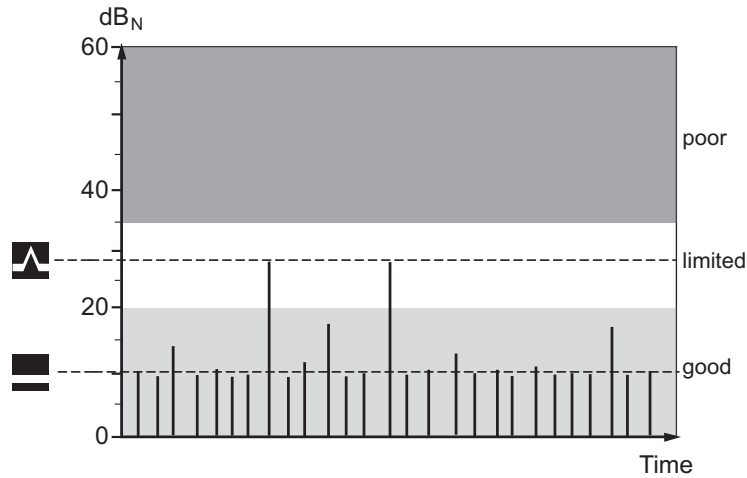

Fig. 2.2.4-3: Limited operating condition

g064512e

A visible increase in the peak values and a rising difference between carpet value and peak values are a sure indication for a bearing damage in progress.

2.2.4.2.3 Poor Operating Condition

Peak values in poor operating condition, a large distance between peak values and carpet values and a possible increase in the carpet value, indicate the presence of a bearing damage.

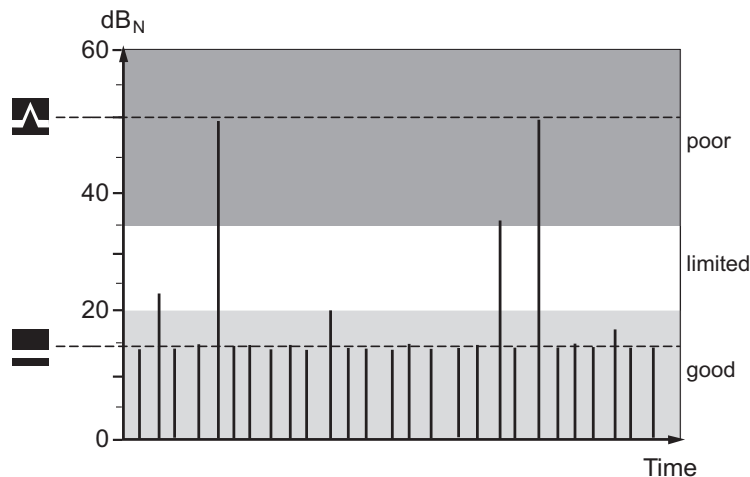

Fig. 2.2.4-4: Poor operating condition

g064513e

When the peak values are in poor operating condition and the peak values are approx. three times the carpet value, the risk of a bearing damage is very high.

2.2.5 Typical Shock Impulse Diagrams

2.2.5.1 Bearing in Good Condition

Peak values between 0 dB_N and 20 dB_N do not require a further analysis. The bearing is in good condition. Brand-new bearings and small needle roller bearings may show values below 0 dB_N. Such low values, however, should be verified since they could be caused by a wrong measuring position or a faulty measurement.

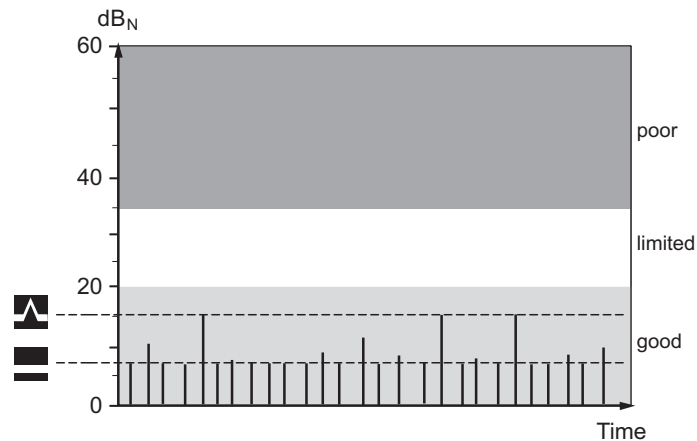

Fig. 2.2.5-1: Bearing on good condition

g064514e



Note

Extremely low measured values may be frequently caused by wrong measuring locations or an erroneous measuring position.

2.2.5.2 Bearing Damage of Foreign Matter in the Lubricant

Occasional high peak values beyond 35 dB_N and a low carpet value indicate that a bearing damage is in progress or that foreign matter is contained in the lubricant. The bearing should be re-lubricated or the lubricant requires analysis, prior to the decision of a bearing exchange.

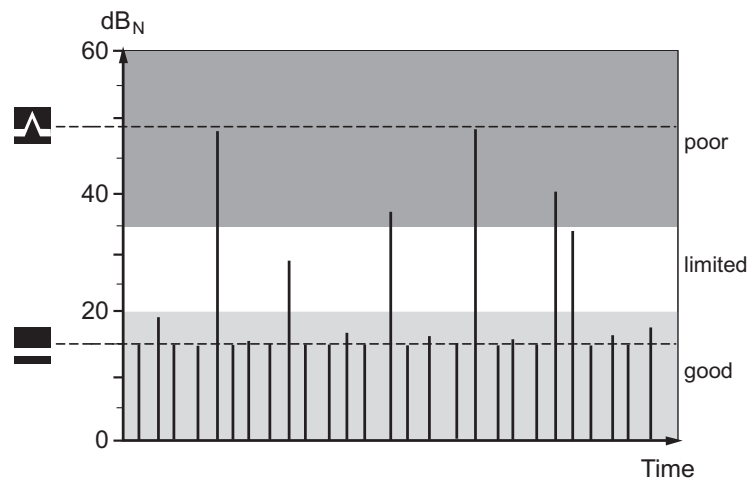

Fig. 2.2.5-2: Bearing damage or foreign matter in the lubricant

g064515e

2.2.5.3 Installation Errors or Insufficient Lubrication

A high carpet value and a peak value insignificantly above, but still in the limited range, indicate either an installation error when the bearing was installed, or insufficient lubrication. The bearing should be re-lubricated and measured again after some hours. If the lubrication was insufficient, the values should decrease. If the bearing was installed wrongly, the measurement values will remain the same.

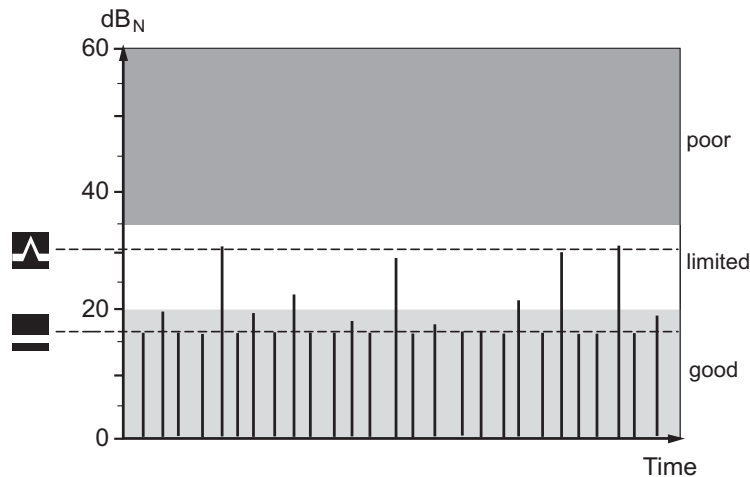

Fig. 2.2.5-3: Installation errors or insufficient lubrication

g064516e

2.2.5.4 Dry-Run or Cavitation

In this diagram, the carpet value and the peak value are very high. This can be caused by dry-run of the bearing or cavitation at a pump. If the cause was dry-run, a re-lubrication of the bearing results in decreased values. In the case of cavitation, the values close to the pump enclosure will be the highest, or will oscillate with the operating point (pressure).

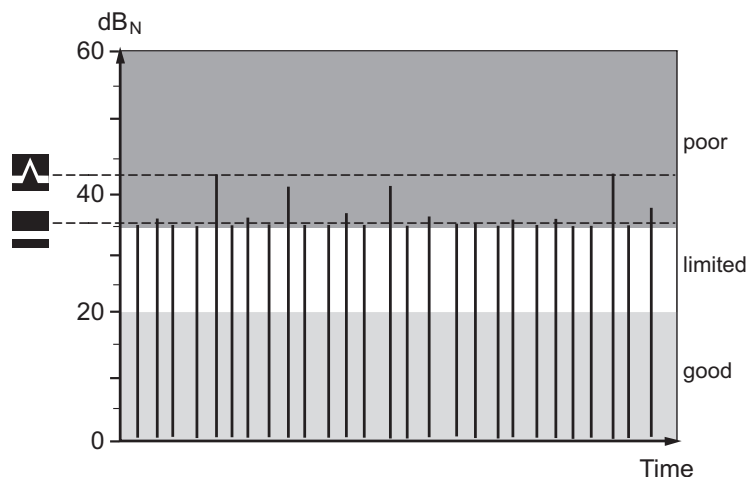

Fig. 2.2.5-4: Dry-run or cavitation

g064517e

2.2.6 The Measuring Point

Preferred measuring location is the place where the shock impulse signals can be received with the least loss. In the case of machinery with rotating masses, the bearing or the bearing enclosure are the ideal measuring locations.

Four rules for the selection of a measuring point

1. Material Transition

Every additional material transition dampens and/or reflects the signal to be measured. The signal path should have one material transition maximum, between bearing and bearing enclosure.

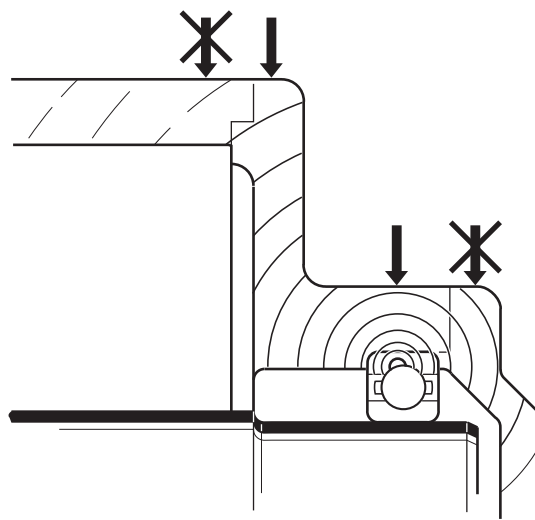

Fig. 2.2.6-1: One material transition

g064524x



Note

Signal losses due to addition material transitions can be significant (i.e., partition lines).

2. Short Measuring Path

The measuring path between bearing and measuring point should be as short and direct as possible.

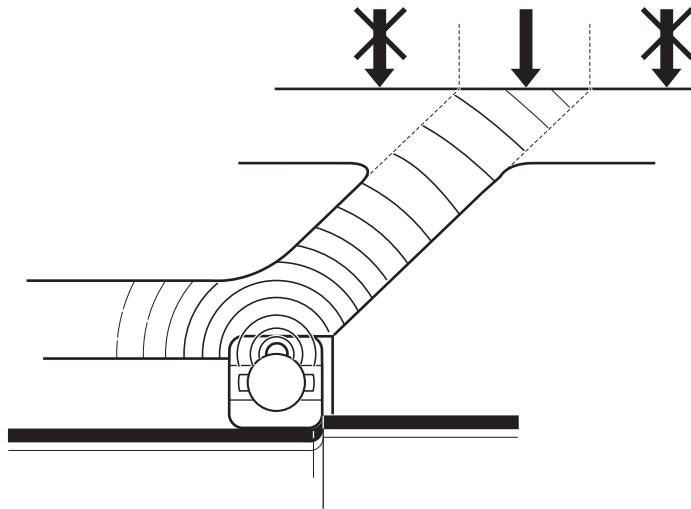

Fig. 2.2.6-2: Short measuring path

g064525x



Note

Shock impulse signals are weakened with increased signal path. Therefore, measurements should be only taken in the dashed area of the drawing.

3. Measurement in Load Direction

Shock impulses are caused by the contact between the roller bearing and the rolling path in the load zone. For this reason, measurements should be taken within the load zone of the bearing, if possible. The load zone is defined by the emission window (see also illustration below). The ideal situation is the measuring point right in the emission window.

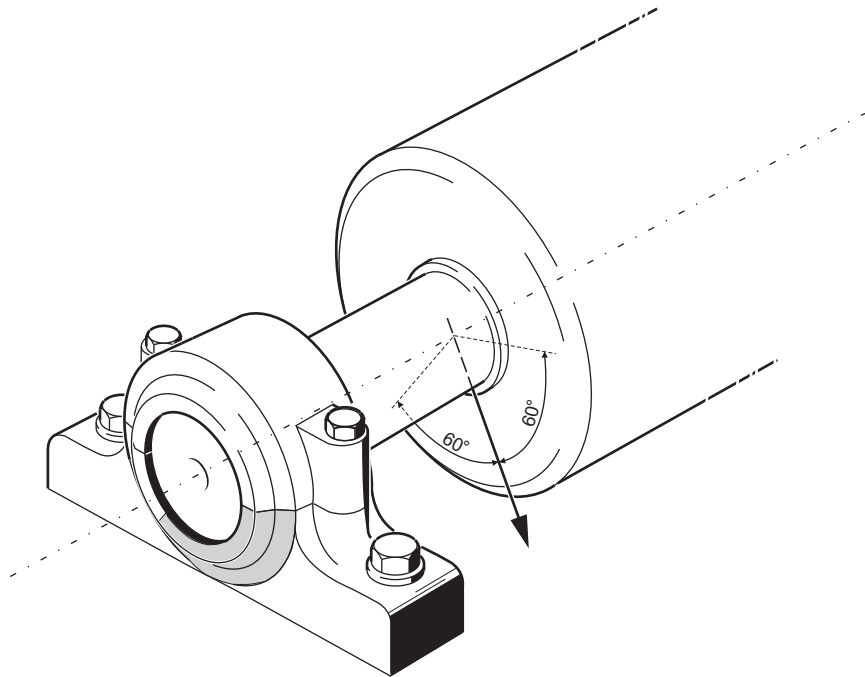

Fig. 2.2.6-3: Measurement in load direction

g064523x

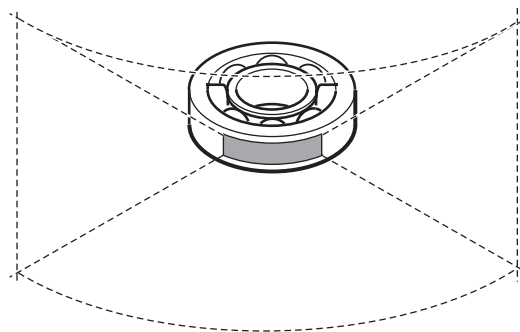

Fig. 2.2.6-4: Emission window

g064522x

Shock impulses spread in waves. The shock impulses are transmitted from the outer rolling path to the bearing enclosure. Because the width of a bearing is limited, shock impulse signals can only be transmitted within a $\pm 60^\circ$ sector from the vertical to the contact surface between roller bearings and rolling path. This area is defined as emission window. Outside an emission window, weakened and reflected signals are measured. These measurements permit trend tracking and comparisons, but will not provide for accurate statements to the lubrication state or possible bearing damages.

4. Measurements as Close to the Bearing as Possible

Shock impulses are weakened by extended measuring paths and material interruptions. Hence, shock impulses should be recorded before an important portion of the signal strength is lost. For this reason, measurements should be taken as close as possible to the bearing.

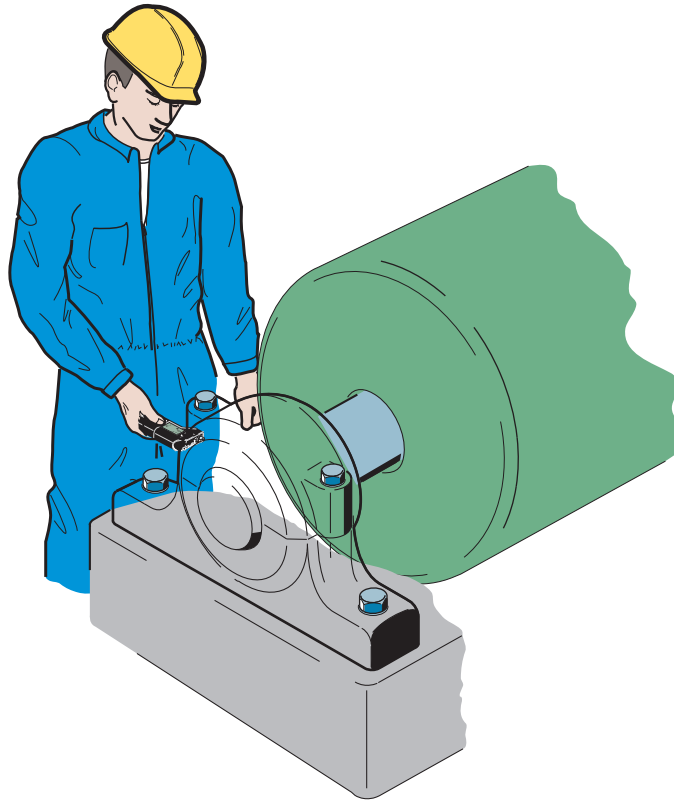

Fig. 2.2.6-5: Measuring location

g064527x



Note

Freely oscillating or elastically malleable enclosure or casing parts, e.g., fan covers, are absolutely unsuitable for measurements.

3 Overview Condition Monitoring Components 750-645, 750-925

Komponente	Artikel-Nr.	Beschreibung
I/O module	750-645	2 channel vibration strength / roller bearing monitoring VIB I/O
Accessories	750-925	Tandem-Piezo® acceleration sensor

4 I/O Modules

4.1 Special Modules

4.1.1 750-645 [2AI/2DO VIB VRMS/SPM Multi]

2 channel vibration strength / roller bearing monitoring VIB I/O

4.1.1.1 View

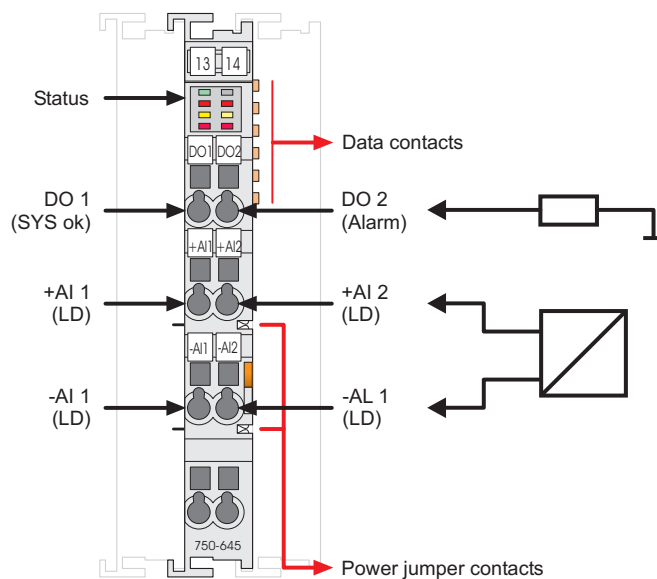

Fig. 4.1.1-1: View

g064500e

4.1.1.2 Description

The VIB-I/O module is used in the online-monitoring of the machine vibration condition. It records the two most important parameters required for the condition analysis: vibration severity and roller bearing condition.

The severity of vibration is a measurement for the machine vibration energy and therefore, a suitable indicator for the vibration forces acting on the machine. The ISO 10816-3 standard is used to assess the results in which the effective values of the (measured) vibration are divided into four quality categories.

The roller bearing condition is evaluated on the basis of high-frequency shock impulse signals. Shock impulses are momentary impulses arising from mechanical damages to roller bearings or the bearing surfaces.

The evaluation uses a scale where the measured shock impulses are divided into three bearing condition categories: 'good', 'limited' and 'poor'. By recording the measurement results and evaluation in a trend curve, bearing damages can be detected at an early time.

A special Tandem-Piezo[®] acceleration sensor at the same time, provides the measurement of machine vibrations and high-frequency shock impulse signals.

The sensor is connected to +AI1 and -AI1 or +AI2 und -AI2 respectively.

The sensor connections are executed as line drive connectors and also provide the power supply to the sensors.

Warning and alarm thresholds can be set for the incoming signals.

The I/O module outputs are short-circuit proof and positive switching. The SYS OK output is "low" active, i.e., the output level is 24 V when there is no error and a warning threshold is not exceeded, and 0 V when a warning threshold is exceeded. The alarm output is "high" active, i.e. the output level is 24 V when an alarm threshold is exceeded.

A green LED signals the fault-free operation of the module and the connected sensors.

Two yellow LEDs indicate the exceeding of a warning threshold, and four red LEDs announce the exceeding of an alarm threshold. The red LEDs also indicate a wire-break or short-circuit.

Field and system signals are electrically isolated.

The individual I/O modules can be arranged in any combination when configuring the fieldbus node. An arrangement in groups is not necessary.

The VIB I/O module receives the 24 VDC supply voltage for the field side via an upstream I/O module or a supply module. Power connections are made automatically from module to module via the internal power jumper contacts when snapped onto the DIN rail.



Note

The 24V field power supply of the VIB-I/O module must be switched on prior to or simultaneously with the system power supply!
If the field supply is switched on after the system supply, the node will not be started!



Warning

The maximum current to flow through the power contacts is 10 A. When configuring the system, it must be assured that this aggregate current is not exceeded. If this should happen, an additional supply module has to be used.

This I/O module can be operated with all couplers/controllers (except the economy variants 750-320, -323, -324 und -327) of the WAGO-I/O-SYSTEM 750.

This description applies to the hardware and software version XXXX????... .
The version is specified in the manufacturing number, which is part of the
lateral marking on the module.

4.1.1.3 Display Elements

LED	Channel	Name	State	Function
SYS ok	-	System state	off	System not OK
			green	System OK
Alarm 1	1	Alarm threshold Channel 1	off	Channel 1 Alarm threshold RMS and SPM not exceeded
			red	Channel 1 Alarm threshold RMS or SPM exceeded
Warn 1	1	Warning threshold Channel 1	off	Channel 1 Warning threshold RMS and SPM not exceeded
			yellow	Channel 1 Warning threshold RMS or SPM exceeded
Error 1	1	Error Channel 1	off	Channel 1 OK
			red	Channel 1 Short-circuit or wire break
Alarm 2	2	Alarm threshold Channel 2	off	Channel 2 Alarm threshold RMS and SPM not exceeded
			red	Channel 2 Alarm threshold RMS or SPM exceeded
Warn 2	2	Warning threshold Channel 2	off	Channel 2 Warning threshold RMS and SPM not exceeded
			yellow	Channel 2 Warning threshold RMS or SPM exceeded
Error 2	2	Error Channel 2	off	Channel 2 OK
			red	Channel 2 Short-circuit or wire break

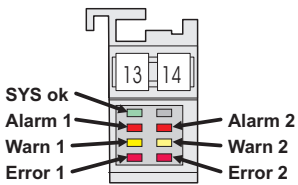

Fig. 4.1.1-2: Display elements
 g064502x

4.1.1.4 Schematic Wiring Diagram

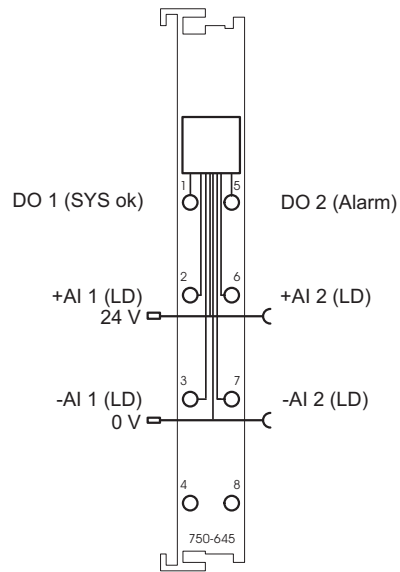





Fig.. 4.1.1-2: Schematic wiring diagram

g064501e

4.1.1.5 Technical Data

Inputs	
Number of inputs	2 (+AI1/-AI1, +AI2/-AI2)
Sensor supply	Line drive
Cable length _{max.}	30 m
Measuring range Vibration speed (RMS) Shock impulse (SPM)	0 ... 100 mm/s -10 ... +80 dB _{SV}
Outputs	
Number of outputs	2 (Alarm, System OK)
Output voltage	DC 24 V
Output current	0.5 A short-circuit proof
Cable length _{max.}	10 m
Configuration	Alarm and warning threshold can be set in the process image or in WAGO-I/O-CHECK
Module Specific Data	
Voltage supply	via system voltage internal bus (5 V) and power jumper contacts field supply (24 V)
Power input (5 V)	< 30 mA
Voltage via power jumper contacts	DC 24 V (-15 % ... +20 %)
Power input (24 V)	< 50 mA + 2 x max. 500 mA load
Isolation	500 V (system/supply)
Internal data width	4 x 16 Bit data 4 x 8 Bit control/status
Dimensions W x H* x D * (from upper edge of DIN 35 rail)	12 mm x 64 mm x 100 mm
Weight	approx. 60 g
Standards and directives (see section 2.2 in manual on coupler / controller)	
EMC CE immunity to interference	as per EN 61000-6-2 (2001)
EMC CE emitted interference	as per EN 61000-6-3 (2001)
Approvals (see section 2.2 in manual on coupler / controller)	
	cUL _{US} (UL508)
	Conformity marking
Accessories	
Tandem-Piezo [®] acceleration sensor or	750-925

The following Ex approvals have been granted to the basic version of 750-645 I/O modules:

 TÜV 07 ATEX 554086 X
 I M2 Ex db I Mb
 II 3 G Ex nAc IIC T4 Gc
 II 3 D Ex tc IIIC T135°C Dc
 Permissible operation temperature: $0\text{ °C} \leq T_A \leq +60\text{ °C}$

 TÜV TUN 09.0001X
 Ex db I Mb
 Ex nAc IIC T4 Gc
 Ex tc IIIC T135°C Dc
 Permissible operation temperature: $0\text{ °C} \leq T_A \leq +60\text{ °C}$



More information

Detailed notes to the approvals are found in the document "Overview WAGO-I/O-SYSTEM 750 Approvals".

This document is found in the CD ROM "AUTOMATION Tools and Docs" (Item No.: 0888-0412) or on the Internet under: <http://www.wago.com> → Documentation → WAGO-I/O-SYSTEM 750 → System description

Additional "General technical data" of the WAGO-I/O-SYSTEM 750 are found in the manual of the corresponding bus system.

4.1.1.6 Function Description

The VIB-I/O module is equipped with a self-monitoring function recognizing a short-circuit at the sensor or an open circuit in the signal path. These faults are signaled after approx. 1-2 seconds via the 'Sys ok'-LED at the module and output via the corresponding 'System OK'-output, independent from the defined delay time.

The VIB-I/O module processes the measured machine signals and compares them with warning and alarm thresholds that are set in parameters. If the level exceeds one of these limiting values and after a user-defined delay time is elapsed, a digital output is activated and the corresponding LED ('Alarm'/'Warn') will light up at the module. The LED and the digital output is only activated when the signal level is continually beyond the defined threshold value.

A delay time for a warning/alarm condition can be defined, after which the corresponding output and LED is activated. This prevents short-time signal peaks, such as those which occur during the start-up of machine, that will trigger a warning or an alarm.

If the signal level rises beyond the defined alarm threshold and the delay time is elapsed, the alarm output changes from 0 V to 24 V. When the signal returns below the alarm threshold, the alarm output will be set back to 0 V after approx. 3 to 4 seconds.

The output 'System ok' will fall from 24 V to 0 V in the case of faults (open circuit, short-circuit, power failure) and also when exceeding the defined warning threshold and delay time is elapsed. When the fault is corrected or the machine again runs in normal range, the output will return to 24 V after 3 to 4 seconds.

4.1.1.6.1 Operating Mode

The following operating modes can be set for each channel:

- No measurement
- Vibration monitoring
- Roller bearing monitoring
- Vibration monitoring and roller bearing monitoring



Please note

If the I/O module is to be used in machine protection, only one channel may be operated in Vibration monitoring mode, the other channel must be turned off (no measurement).

When using the module in condition monitoring, both channels may be used in any combination of operating modes.

4.1.1.6.1.1 Messablauf im Einkanal-Betrieb

Im Einkanal-Betrieb wird nach einer einmaligen Settling Time (t_s) von 10 Sekunden Dauer kontinuierlich gemessen.



Abb. 4.1.1-2: Messablauf im Einkanal-Betrieb

g064540d

4.1.1.6.1.2 Messablauf im Zweikanal-Betrieb

Im Zweikanal-Betrieb mit zwei Sensoren an beiden aktivierten Kanälen (über WAGO-I/O-CHECK konfigurierbar) werden die Sensor-Messdaten dieser beiden Kanäle sequentiell abgearbeitet.

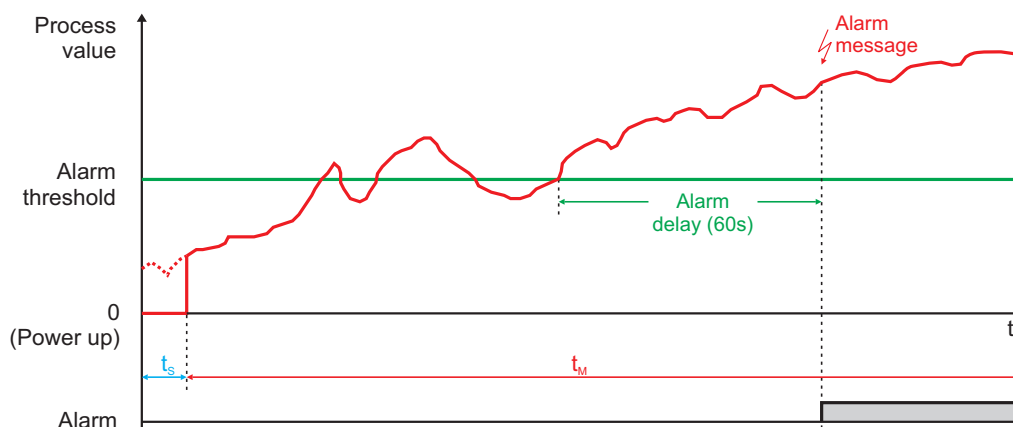
- a) Nach einer internen Kanalumschaltung läuft auf nur einem Kanal die Settling Time (t_s) von 10 Sekunden Dauer ab, in der das Messsignal auf Grund von Filtern einschwingen muss. Während dieser 10 Sekunden werden die Prozessdaten zur Steuerung auf beiden Kanälen nicht aktualisiert (eingefroren).

b) Anschließend beginnt die eigentliche Messzeit (t_M) von 20 Sekunden Dauer, während der die Prozessdaten zur Steuerung aktualisiert werden.

c, d) Nach 30 Sekunden findet ein Kanalwechsel statt. Die Prozessdaten des bis jetzt aktiven Kanals werden auf dem letzten gültigen Prozesswert eingefroren. Auf dem nun aktivierten anderen Kanal ist der nun folgende Ablauf identisch mit a) und b).

	Duration	Activity Channel 1	Activity Channel 2	Total Duration
a)	$t_S = 10$ s	„Settling time“ channel 1 (frozen process data)	Frozen process data	10 s
b)	$t_M = 20$ s	Measuring channel 1		30 s
c)	$t_S = 10$ s	Frozen process data	„Settling time“ channel 2 (frozen process data)	40 s
d)	$t_M = 20$ s		Measuring channel 2	60 s



Abb. 4.1.1-2: Messablauf im Zweikanal-Betrieb

g064541d

4.1.1.6.2 Parameter Vibration Monitoring (RMS)

The following parameters can be defined for each channel for the vibration monitoring:

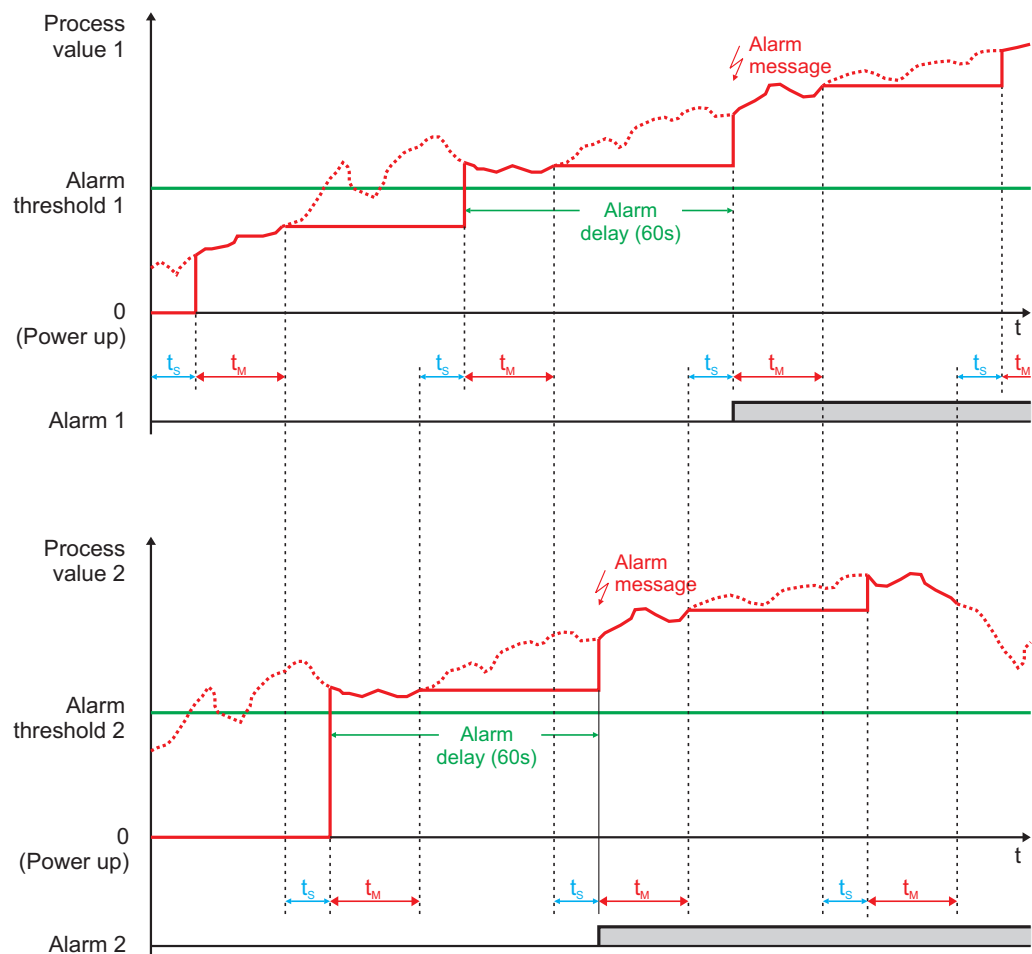
- Lower limiting frequency (2 Hz or 10 Hz)
- Alarm threshold (0 mm/s ... measuring range end value)
- Warning threshold (0 mm/s ... measuring range end value)
- Delay time alarm (0 ... 600 s)
- Delay time warning (0 ... 600 s)

4.1.1.6.3 Parameter Roller Bearing Monitoring (SPM)

The following parameters can be defined for each channel for the roller bearing monitoring:

- Measuring range end value (40 dBSV, 60 dBSV, 80 dBSV)
- Alarm threshold (-10 dB_{SV} ... measuring range end value)
- Warning threshold (-10 dB_{SV} ... measuring range end value)
- Delay time alarm (0 ... 600 s)
- Delay time warning (0 ... 600 s)

4.1.1.7 Process Image

The 750-645 I/O module provides the fieldbus coupler/controller 12 byte input and output process image via 4 logical channels.

The measuring values for channel 1 are transmitted via the data bytes D0 and D1, or D4 and D5, respectively, and the measuring values for channel 2 are transmitted via the data bytes D2 and D3 or D6 and D7, respectively. The status messages for channel 1 are transmitted via the status bytes S0 and S2, whereas the status messages for channel 2 are transmitted using status bytes S1 and S3.



Please note

Mapping the process data of some I/O modules or their variations into the process image is specific for the fieldbus coupler/controller used. You will find both this information and the specific configuration of the relevant control/status bytes in the section on "Fieldbus Specific Configuration of Process Data" which describes the process image of the particular coupler/controller.

4.1.1.7.1 Overview

Input Data		Output Data	
S0	Status byte S0	C0	Control byte C0
D0	Channel 1 RMS Vibration force [mm / s x 10] (LSB)	D0	reserved
D1	Channel 1 RMS Vibration force [mm / s x 10] (MSB)	D1	reserved
S1	Status byte S1	C1	Control byte C1
D2	Channel 2 RMS Vibration force [mm / s x 10] (LSB)	D2	reserved
D3	Channel 2 RMS Vibration force [mm / s x 10] (MSB)	D3	reserved
S2	Status byte S2	C2	Control byte C2
D4	Channel 1 SPM Peak [dB _{sv}]	D4	reserved
D5	Channel 1 SPM Carpet [dB _{sv}]	D5	reserved
S3	Status byte S3	C3	Control byte C3
D6	Channel 2 SPM Peak [dB _{sv}]	D6	reserved
D7	Channel 2 SPM Carpet [dB _{sv}]	D7	reserved

4.1.1.7.2 Control and Status Byte in Process Data Communication

For process data communication, Bit 7 (REG_COM) must be set to '0' in the corresponding control byte. Control and status bytes will then be assigned as follows:

Control byte C0							
Bit 7	Bit 6	Bit 5	Bit 4	Bit 3	Bit 2	Bit 1	Bit 0
REG_COM	0	0	0	0	0	0	0
REG_COM	0:	Process data communication					
0	reserved						

Control byte C1							
Bit 7	Bit 6	Bit 5	Bit 4	Bit 3	Bit 2	Bit 1	Bit 0
REG_COM	0	0	0	0	0	0	0
REG_COM	0:	Process data communication					
0	reserved						

Control byte C2							
Bit 7	Bit 6	Bit 5	Bit 4	Bit 3	Bit 2	Bit 1	Bit 0
REG_COM	0	0	0	0	0	0	0
REG_COM	0:	Process data communication					
0	reserved						

Control byte C3							
Bit 7	Bit 6	Bit 5	Bit 4	Bit 3	Bit 2	Bit 1	Bit 0
REG_COM	0	0	0	0	0	0	0
REG_COM	0:	Process data communication					
0	reserved						

Status byte S0							
Bit 7	Bit 6	Bit 5	Bit 4	Bit 3	Bit 2	Bit 1	Bit 0
REG_COM	ERROR	X	ALARM	ERR_K1	WRN_K1	AL_K1	SYS_OK
SYS_OK	0:	System OK, System-OK output is set					
	1:	System not OK					
AL_K1	0:	OK					
	1:	Channel 1 alarm threshold (RMS or SPM) exceeded					
WRN_K1	0:	OK					
	1:	Channel 1 warning threshold (RMS or SPM) exceeded					
ERR_K1	0:	OK					
	1:	Channel 1 error (wire break, short-circuit)					
ALARM	0:	OK					
	1:	Alarm output is set, OR linkage with AL_Kx					
ERROR	0:	OK					
	1:	General error, OR linkage of POST (PowerOn SelfTest) and ERR_Kx. Warning and alarm messages are not output. Not identical to SYS-OK, only reports error of the module including sensor					
REG_COM	0:	Process data communication					
X	reserved						

Status byte S1							
Bit 7	Bit 6	Bit 5	Bit 4	Bit 3	Bit 2	Bit 1	Bit 0
REG_COM	ERROR	X	ALARM	ERR_K2	WRN_K2	AL_K2	SYS_OK
SYS_OK	0:	System OK, System-OK output is set					
	1:	System not OK					
AL_K2	0:	OK					
	1:	Channel 2 alarm threshold (RMS or SPM) exceeded					
WRN_K2	0:	OK					
	1:	Channel 2 warning threshold (RMS or SPM) exceeded (red LED "WARN 2" on)					
ERR_K2	0:	OK					
	1:	Channel 2 error (wire break, short-circuit)					
ALARM	0:	OK					
	1:	Alarm output is set, OR linkage with AL_Kx					
ERROR	0:	OK					
	1:	General error, OR linkage of POST (PowerOn SelfTest) and ERR_Kx. Warning and alarm messages are not output. Not identical to SYS-OK, only reports error of the module including sensor					
REG_COM	0:	Process data communication					
X	Reserved						

Status byte S2							
Bit 7	Bit 6	Bit 5	Bit 4	Bit 3	Bit 2	Bit 1	Bit 0
REG_COM	ERROR	RMS_SPM_AL	SENS_ERR_K1	SPM_AL_K1	SPM_WRN_K1	RMS_AL_K1	RMS_WRN_K1
RMS_WRN_K1	0:	OK					
	1:	Channel 1 RMS warning threshold exceeded					
RMS_AL_K1	0:	OK					
	1:	Channel 1 RMS alarm threshold exceeded					
SPM_WRN_K1	0:	OK					
	1:	Channel 1 SPM warning threshold exceeded					
SPM_AL_K1	0:	OK					
	1:	Channel 1 SPM alarm threshold exceeded					
SENS_ERR_K1	0:	OK					
	1:	Channel 1 sensor short-circuit or wire break					
RMS_SPM_AL	0:	OK					
	1:	Alarm output is set, OR linkage of RMS_AL_Kx and SPM_AL_Kx					
ERROR	0:	OK					
	1:	General error, OR linkage of POST (PowerOn SelfTest) and ERR_Kx. Warning and alarm messages are not output. Not identical to SYS-OK, only reports error of the module including sensor					
REG_COM	0:	Process data communication					

Status byte S3							
Bit 7	Bit 6	Bit 5	Bit 4	Bit 3	Bit 2	Bit 1	Bit 0
REG_COM	ERROR	RMS_SPM_AL	SENS_ERR_K2	SPM_AL_K2	SPM_WRN_K2	RMS_AL_K2	RMS_WRN_K2
RMS_WRN_K2	0:	OK					
	1:	Channel 2 RMS warning threshold exceeded					
RMS_AL_K2	0:	OK					
	1:	Channel 2 RMS alarm threshold exceeded					
SPM_WRN_K2	0:	OK					
	1:	Channel 2 SPM warning threshold exceeded					
SPM_AL_K2	0:	OK					
	1:	Channel 2 SPM alarm threshold exceeded					
SENS_ERR_K2	0:	OK					
	1:	Channel 2 sensor short-circuit or wire break					
RMS_SPM_AL	0:	OK					
	1:	Alarm output is set, OR linkage of RMS_AL_Kx and SPM_AL_Kx					
ERROR	0:	OK					
	1:	General error, OR linkage of POST (PowerOn SelfTest) and ERR_Kx. Warning and alarm messages are not output. Not identical to SYS-OK, only reports error of the module including sensor					
REG_COM	0:	Process data communication					

4.1.1.8 Setting the 750-645 Module Using Register Communication

The operating mode and the parameters for the 750-645 module can be set using the register communication.

The values for channel 1 are set via the control and status bytes C0/S0 for the addressing and via the data bytes D0 and D1 for the transmission of the values to be set. The settings for channel 2 are made via the control and status bytes C1/S1 and the data bytes D2 and D3.

Setting Parameters				
Channel	Function	Control-/status byte	Register	Data bytes
1	Operating mode	C0/S0	41	D0/D1
	2 Hz/10 Hz change-over	C0/S0	42	D0/D1
	Measuring range SPM	C0/S0	43	D0/D1
	Alarm threshold RMS	C0/S0	48	D0/D1
	Delay alarm RMS	C0/S0	49	D0/D1
	Warning threshold RMS	C0/S0	50	D0/D1
	Delay warning RMS	C0/S0	51	D0/D1
	Alarm threshold SPM	C0/S0	52	D0/D1
	Delay alarm SPM	C0/S0	53	D0/D1
	Warning threshold SPM	C0/S0	54	D0/D1
	Delay warning SPM	C0/S0	55	D0/D1
2	Operating mode	C1/S1	41	D2/D3
	2 Hz/10 Hz change-over	C1/S1	42	D2/D3
	Measuring range SPM	C1/S1	43	D2/D3
	Alarm threshold RMS	C1/S1	48	D2/D3
	Delay alarm RMS	C1/S1	49	D2/D3
	Warning threshold RMS	C1/S1	50	D2/D3
	Delay warning RMS	C1/S1	51	D2/D3
	Alarm threshold SPM	C1/S1	52	D2/D3
	Delay alarm SPM	C1/S1	53	D2/D3
	Warning threshold SPM	C1/S1	54	D2/D3
	Delay warning SPM	C1/S1	55	D2/D3

Setting the 750-645 Module Using Register Communication

The following table displays the assignments and factory settings for the individual registers.

Register Assignment				
Register	Function	Data type	Access	Factory setting
41	Bit 0 ... 1: Mode 0: no measurement 1: RMS measurement 2: SPM measurement 3: RMS + SPM measurement Bit 2 ... 15: reserved	Flags	R/W	Channel 1 / Sensor 1: [0x0003] = RMS and SPM Channel 2 / Sensor 2: [0x0000] = no measurement
42	Bit 0 ... 6: reserved Bit 7: 2/10 Hz Change-over 0: 10 – 1000 Hz 1: 2 – 1000 Hz Bit 8 ... 15: reserved	Flags	R/W	[0x0000] = Frequency range 10 – 1000 Hz
43	Bit 0 ... 3: Measuring range SPM 0: to +80 dBsv 1: to +60 dBsv 2: to +40 dBsv Bit 4 ... 15: reserved	Flags	R/W	[0x0000] = Measuring range SPM to +80 dBsv
44	Reserved	UINT	R/W	[0xXXXX]
45	Reserved	UINT	R/W	[0xXXXX]
46	Reserved	UINT	R/W	[0xXXXX]
47	Reserved	UINT	R/W	[0xXXXX]
48	Alarm threshold RMS [mm/s x 10]	UINT	R/W	[0x0096] = 15,0 mm/s
49	Delay alarm RMS [s]	UINT	R/W	[0x000A] = 10 seconds
50	Warning threshold RMS [mm/s x 10]	UINT	R/W	[0x0064] = 10.0 mm/s
51	Delay warning RMS [s]	UINT	R/W	[0x001E] = 30 seconds
52	Alarm threshold SPM [dBsv]	UINT	R/W	[0x0041] = 65 dBsv
53	Delay alarm SPM [s]	UINT	R/W	[0x000A] = 10 seconds
54	Warning threshold SPM [dBsv]	UINT	R/W	[0x0037] = 55 dBsv
55	Delay warning SPM [s]	UINT	R/W	[0x001E] = 30 seconds



Please note

Prior to writing to the registers, '0x1235' must be written to the password register 31.

Bit 0 to Bit 5 of the control byte contain the register number.

The access direction (read/write) is set with Bit 6 (R/W) of the control byte.

In order to activate the register communication, Bit 7 (REG_COM) in the control byte is set to '1'.

The values to be set are written to the output data bytes D0 and D1 and can be read back with the input data bytes D0 and D1.



Please note

After writing to the registers, the set values should be verified by reading the registers.

The corresponding bits of the control byte are mirrored in Bit0 to Bit 5 and Bit 7 of the status byte.



Please note

After writing to the registers, the password register 31 must be reset with '0x0000'. Otherwise write access to these registers is possible until the supply voltage is disconnected.

4.1.1.8.1 Control- and Status Byte at Register Communication

The following tables show the assignment of the control and status bytes.

Control byte C0							
Bit 7	Bit 6	Bit 5	Bit 4	Bit 3	Bit 2	Bit 1	Bit 0
REG_COM	R/W	Register number					
Register number	Register number of selected function (see Table "Setting parameters")						
R/W	0:	Read access					
	1:	Write access					
REG_COM	1:	Register communication					

Control byte C1							
Bit 7	Bit 6	Bit 5	Bit 4	Bit 3	Bit 2	Bit 1	Bit 0
REG_COM	R/W	Register number					
Register number	Register number of selected function (see Table "Setting Parameters")						
R/W	0:	Read access					
	1:	Write access					
REG_COM	1:	Register communication					

Setting the 750-645 Module Using Register Communication

Control byte C2							
Bit 7	Bit 6	Bit 5	Bit 4	Bit 3	Bit 2	Bit 1	Bit 0
Not used for register communication.							

Control byte C3							
Bit 7	Bit 6	Bit 5	Bit 4	Bit 3	Bit 2	Bit 1	Bit 0
Not used for register communication.							

Status byte S0							
Bit 7	Bit 6	Bit 5	Bit 4	Bit 3	Bit 2	Bit 1	Bit 0
REG_COM	X	Register number					
Register number	Register number of selected function (see Table "Setting Parameters"), mirrored from control byte 0						
REG_COM	1:	Register communication (mirrored from control byte C0)					
X	Reserved						

Status byte S1							
Bit 7	Bit 6	Bit 5	Bit 4	Bit 3	Bit 2	Bit 1	Bit 0
REG_COM	X	Register number					
Register number	Register number of selected function (see Table "Setting Parameters"), mirrored from control byte 1						
REG_COM	1:	Register communication (mirrored from control byte C1)					
X	reserved						

Status byte S2							
Bit 7	Bit 6	Bit 5	Bit 4	Bit 3	Bit 2	Bit 1	Bit 0
Not used for register communication.							

Status byte S3							
Bit 7	Bit 6	Bit 5	Bit 4	Bit 3	Bit 2	Bit 1	Bit 0
Not used for register communication.							

4.1.1.9 Setting the 750-645 Module with WAGO-I/O-CHECK 2

Select the module in node view or in navigation.

Open the parameter dialog of the selected module. To do so, execute the command *Settings* in the context menu of the module (node view or navigation).

The following dialog appears:

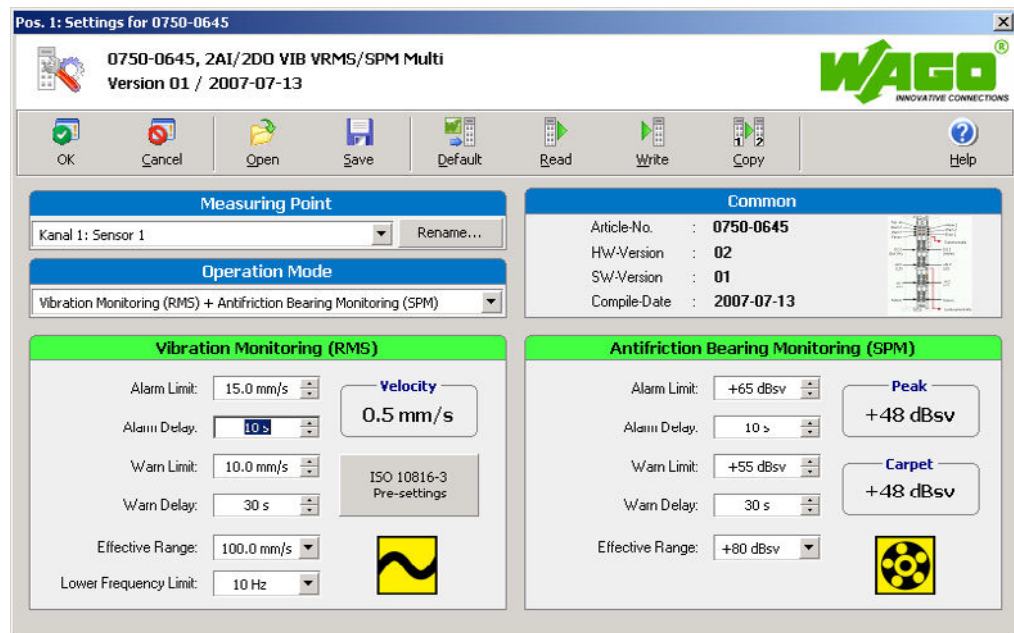

Fig. 4.1.1-2: Settings dialog

p064510e



Note:

Before changing the parameters you should save the current values in a parameter file. In case that the parameters are wrong, you can always fall back on the original values. Use the **SAVE** and **OPEN** buttons in the parameter dialog.

When opening the parameter dialog, the current parameter set of the I/O module is read out of the module's EEPROM and displayed.

If you want to use already existing data, click the **OPEN** button.

In the **OPEN** dialog, enter a name for the parameter file and select the directory from which the file is to be loaded. Now click on **OPEN** in order to load the file from the hard disk.

You can now make the required changes.

Select the required channel in the *Measuring Point* group. If necessary, change the channel name.

Select the required Operating mode in the *Operating Mode* group.

Enter the required limiting values and delay times in the *Vibration Monitoring* group (*RMS*).



Note:

The value *Effective Range* must not be changed!

If you click on a parameter value with the left mouse button a selection list of the possible settings for this parameter will be displayed. You can also enter the desired value directly.

If warning or alarm thresholds are exceeded, the title bars of the corresponding group are displayed in yellow or red.

By clicking on the **ISO 10816-3 PRE-SETTINGS** button, you open a dialog box where you can select a default setting of the values specified for the machine type.



Abb. 4.1.1-2: Default setting dialog

p064511d

The classification is made by machine and foundation type.

Enter the required limiting values and delay times in the *Antifriction Bearing Monitoring* group (*SPM*).

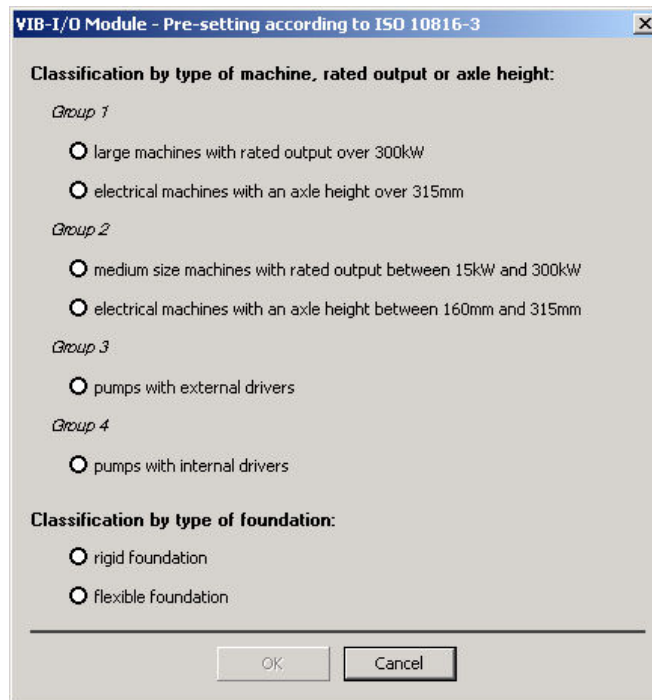
After changing the required parameters, transfer them into the I/O module. To do so, click on **WRITE** in the toolbar.

If all settings are correct, save the parameter set in a parameter file. To do so, click on **STORE**.

In the *Save under* dialog, enter a name for the parameter file and select the directory in which the file is to be saved. Now click on **STORE** in order save the file on the hard disk.

In order to close the parameter dialog click on **EXIT**.

5 Accessories

5.1 Sensors

5.1.1 750-925 [Tandem-Piezo® Acceleration Sensor]

5.1.1.1 View

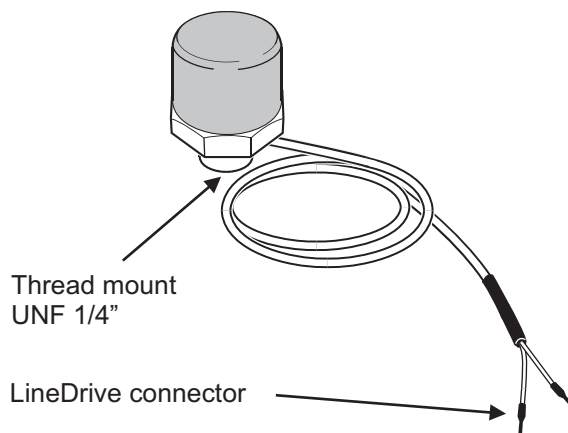

Fig. 5.1.1-1: View

g092500e



5.1.1.2 Description

The Series 750-925 Tandem-Piezo® sensor is designed for continuous monitoring of machine vibration. It is suitable for vibration measurement up to 10 KHz, shock pulse measurement on rolling bearings, as well as pump cavitation measurement.

The sensor features a ¼“ UNF thread mount and can be fitted to the machine part to be monitored using either screwed adapters (in the scope of supply), bonded adapters or magnetic adapters.

The sensor is equipped with a LineDrive connector and operates in conjunction with the Series 750-645 VIB I/O module.

5.1.1.3 Technical Data

Technical Data	
Signaling system	Current LineDrive, 3.5 mA closed current with superposed AC signal
Measurement range (r.m.s.) _{max.}	961 ms ⁻²
Transmission factor ±5 %	1.0 μA/ms ⁻² (159 Hz, 25 °C)
Frequency range ±10 % ± 3 dB	4 Hz ... 8 kHz 2 Hz ... 10 kHz
Resonant frequency	30 kHz
Linearity range ±10 %	±961 ms ⁻² (±98 g)
Temperature range	-30 °C ... +80 °C
Power requirement	3.5 mA DC/8.5 ... 18 V DC
Temperature sensitivity	< 0.08 ms ⁻² /K
Electrical noise, rms (2 Hz ... 10 kHz)	< 0.1 ms ⁻²
Output impedance	> 250 kOhm
Shock limit _{max.}	250 kms ⁻²
Housing material	VA 1.4305/Peek 1000
Degree of protection	IP65 (with cable)
Mounting	UNF ¼" thread
Connector type	Coaxial, open cable ends
Cable length	6 m
Weight	22 g
Standards and Regulations (See Section 2.2 of the Coupler/Controller Manual)	
EMC Immunity to interference	acc. to EN 61000-6-2 (2001)
EMC Emission of interference	acc. to EN 61000-6-3 (2001)
Approvals (See Section 2.2 of the Coupler/Controller Manual)	
	cUL _{US} (UL508)
	Conformity marking
Accessories	
Screwed adapter M8, 90°	in the scope of supply
Bonded adapter	on request
Magnetic adapter	on request

Dimensions

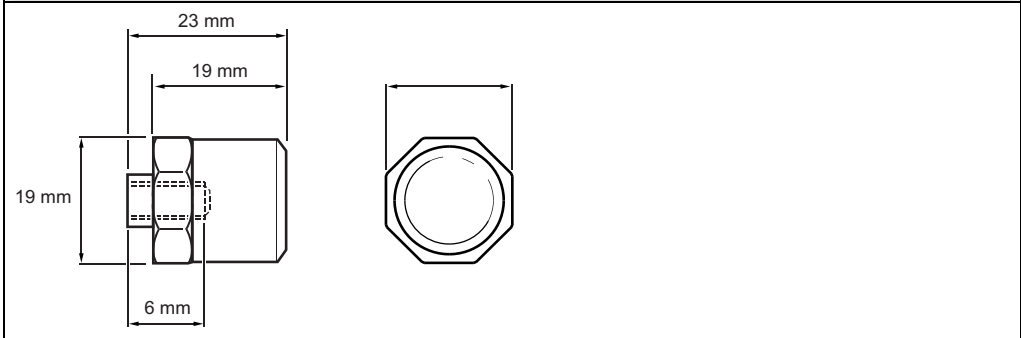

Fig. 5.1.1-2: Dimensions

g092503x

Frequency Response Curve

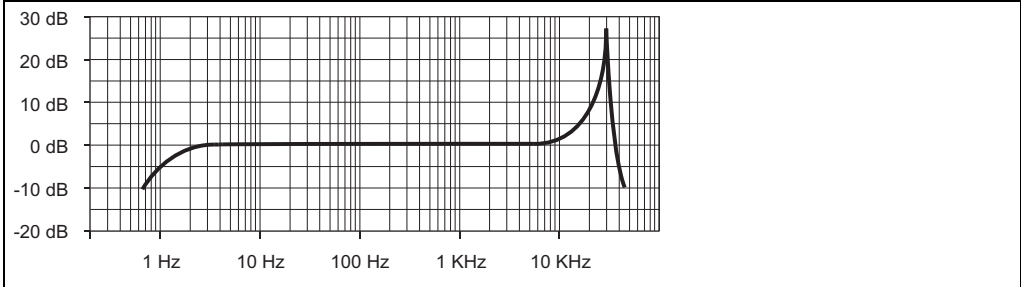

Fig. 5.1.1-3: Frequency response curve

g092504x

5.1.1.4 Screwed Adapter with M8 Thread

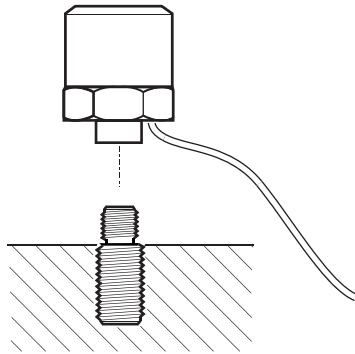

Fig. 5.1.1-4: Sensor with screwed adapter

g092505x

Step 1: Select hole position

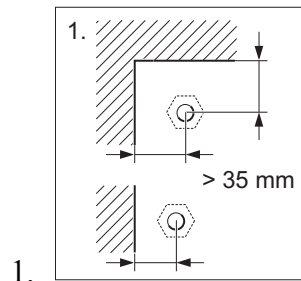

Fig. 5.1.1-5: Assembly step 1

g092510x

Step 2: Bore pilot hole

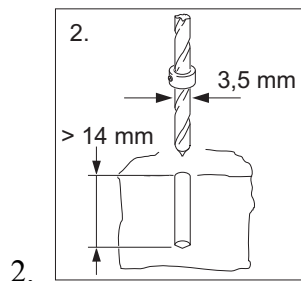

Fig. 5.1.1-6: Assembly step 2

g092511x

Step 3: Bore out hole

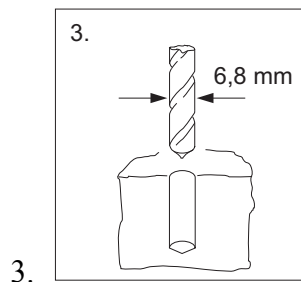
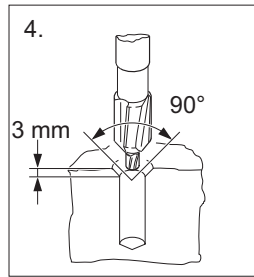

Fig. 5.1.1-7: Assembly step 3

g092512x

Step 4: Countersink hole



4.
Fig. 5.1.1-8: Assembly step 4

g092513x

Step 5: Tap thread

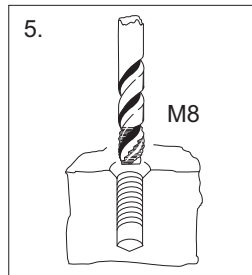

Fig. 5.1.1-9: Assembly step 5

g092514x

Step 6: Mount adapter

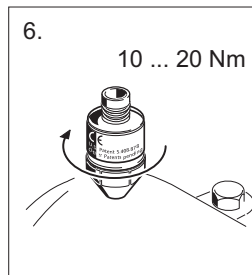

Fig. 5.1.1-10: Assembly step 6

g092515x

5.1.1.5 Electrical Connection

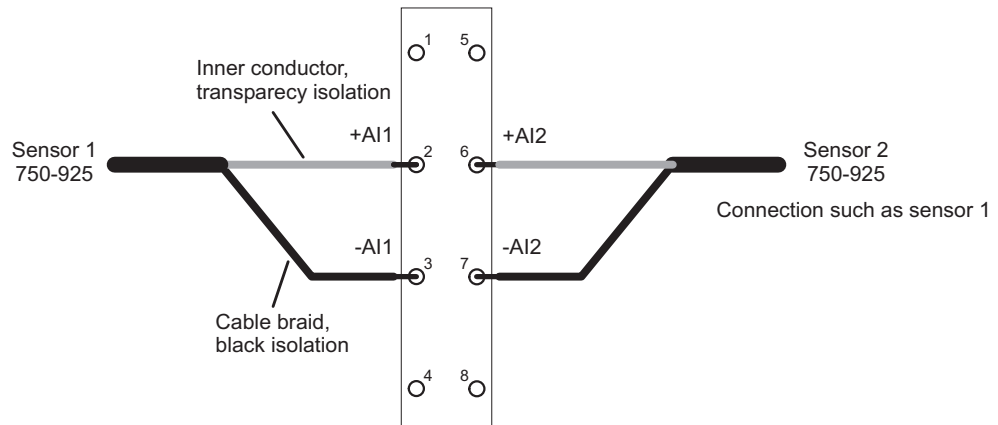

Fig. 5.1.1-11: Electrical connection



g092508e

5.1.1.6 Measurement Report Template

On the following page, you will find the template of a measurement report on a measuring point of the VIB I/O module 750-645. You can copy or print this template as you need it.

The measurement report will help you to report and archive the settings done. Enter all the values related to a measuring point into the table (including date and signature) and keep the measurement protocol together with your machine documentation.

This way, if the settings have been changed unintentionally, you can reset the module to its original values.

VIB I/O Module 750-645 with Tandem-Piezo® Sensor 750-925		
Measuring point		
	Vibration Measurement RMS	
Measuring range	[mm / s * 10]	
Reference	[mm / s * 10]	
Warning threshold	[mm / s * 10]	
Warning delay	[s]	
Alarm threshold	[mm / s * 10]	
Alarm delay	[s]	
	Shock Pulse Measurement (SPM)	
Measuring range	[dB _{sv}]	
Reference	[dB _{sv}]	
Warning threshold	[dB _{sv}]	
Warning delay	[s]	

56 • 750-925 [Tandem-Piezo® Acceleration Sensor]
Measurement Report Template

Alarm threshold	[dB _{sv}]
Alarm delay	[s]
Date	
Signature	

6 Use in Hazardous Environments

The **WAGO-I/O-SYSTEM 750** (electrical equipment) is designed for use in Zone 2 hazardous areas.

The following sections include both the general identification of components (devices) and the installation regulations to be observed. The individual subsections of the "Installation Regulations" section must be taken into account if the I/O module has the required approval or is subject to the range of application of the ATEX directive.

6.1 Marking Configuration Examples

6.1.1 Marking for Europe according to CENELEC and IEC

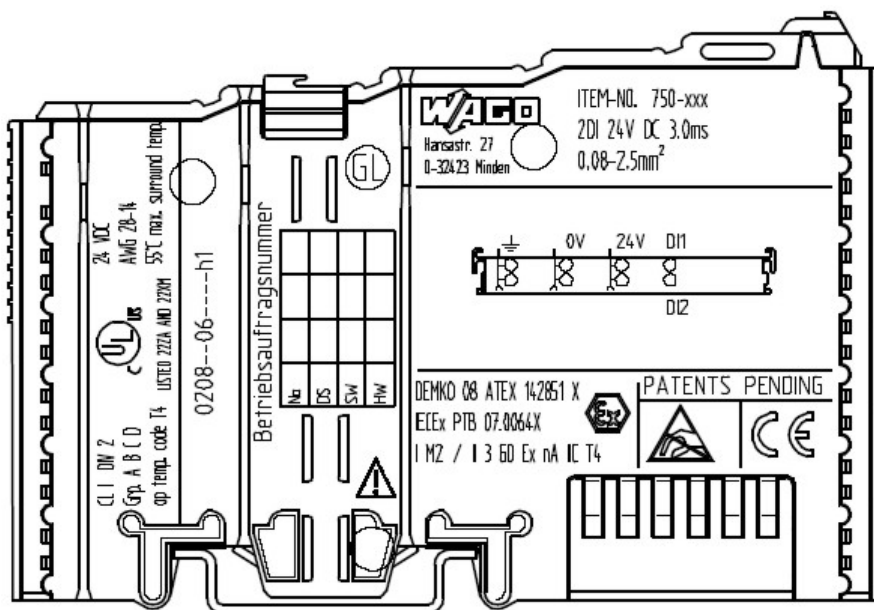

Figure 1: Side marking example for ATEX and IEC Ex approved I/O modules according to CENELEC and IEC

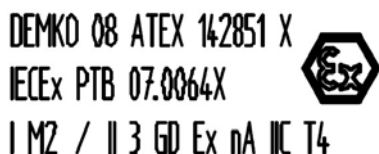

Figure 2: Printing Text detail – Marking example for ATEX and IEC Ex approved I/O modules according to CENELEC and IEC

Table 1: Description of marking example for ATEX and IEC Ex approved I/O modules according to CENELEC and IEC

Printing on Text	Description
DEMKO 08 ATEX 142851 X IECEX PTB 07.0064X	Approval body and/or number of the examination certificate
I M2 / II 3 GD	Explosion protection group and Unit category
Ex nA	Type of ignition and extended identification
IIC	Explosion protection group
T4	Temperature class

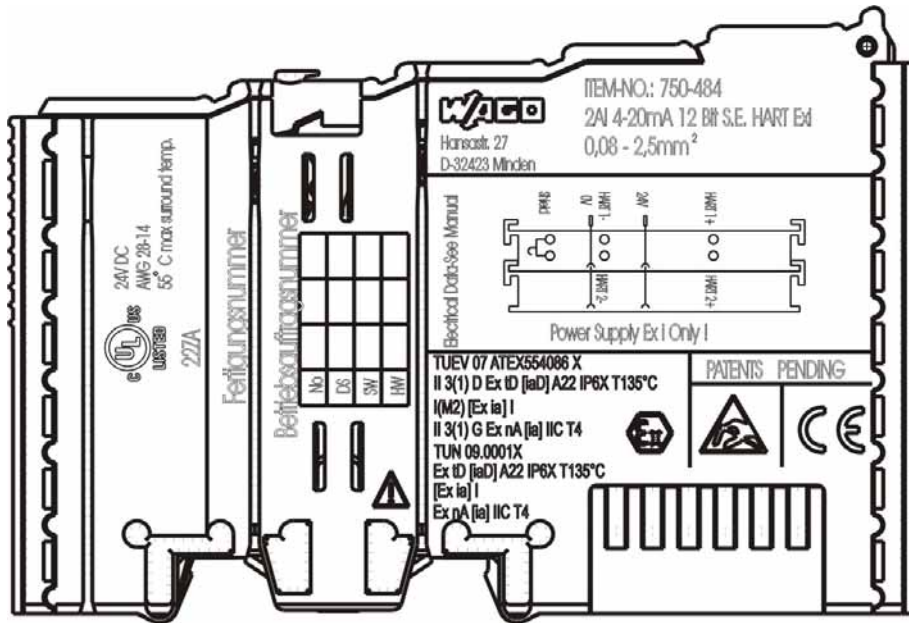

Figure 3: Side marking example for Ex i and IEC Ex i approved I/O modules according to CENELEC and IEC

TUEV 07 ATEX554086 X
II 3(1) D Ex tD [IaD] A22 IP6X T135°C
I(M2) [Ex ia] I
II 3(1) G Ex nA [Ia] IIC T4
TUN 09.0001X
Ex tD [IaD] A22 IP6X T135°C
[Ex ia] I
Ex nA [Ia] IIC T4



Figure 4: Text detail – Marking example for Ex i and IEC Ex i approved I/O modules according to CENELEC and IEC

Table 2: Description of marking example for Ex i and IEC Ex i approved I/O modules according to CENELEC and IEC

Inscription text	Description
TÜV 07 ATEX 554086 X TUN 09.0001X	Approving authority or certificate numbers
Dust	
II	Device group: All except mining
3(1)D	Device category: Zone 22 device (Zone 20 subunit)
Ex	Explosion protection mark
tD	Protection by enclosure
[iaD]	Approved in accordance with "Dust intrinsic safety" standard
A22	Surface temperature determined according to Procedure A, use in Zone 22
IP6X	Dust-tight (totally protected against dust)
T 135°C	Max. surface temp. of the enclosure (no dust bin)
Mining	
I	Device group: Mining
(M2)	Device category: High degree of safety
[Ex ia]	Explosion protection: Mark with category of type of protection intrinsic safety: Even safe when two errors occur
I	Device group: Mining
Gases	
II	Device group: All except mining
3(1)G	Device category: Zone 2 device (Zone 0 subunit)
Ex	Explosion protection mark
nA	Type of protection: Non-sparking operating equipment
[ia]	Category of type of protection intrinsic safety: Even safe when two errors occur
IIC	Explosion Group
T4	Temperature class: Max. surface temperature 135°C

6.1.2 Marking for America according to NEC 500

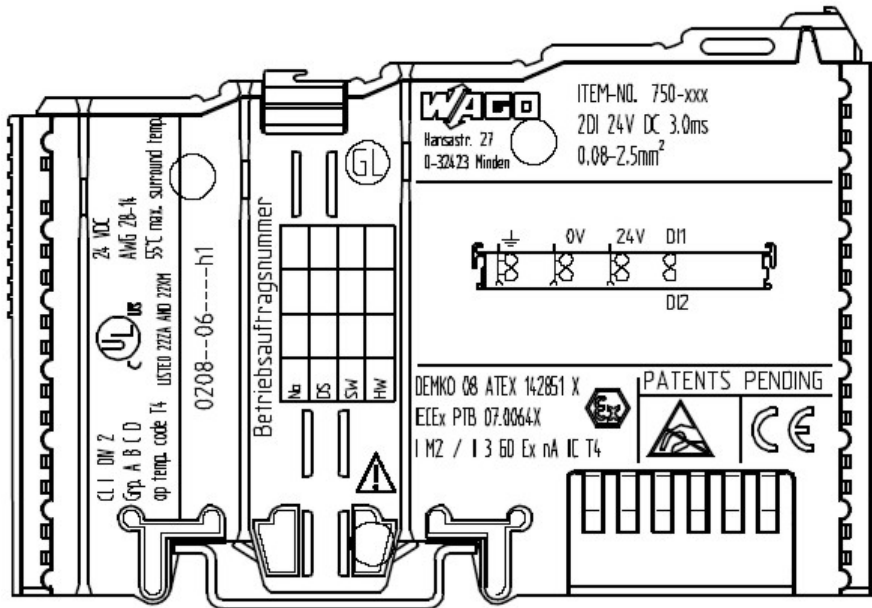

Figure 5: Side marking example for I/O modules according to NEC 500



Figure 6: Text detail – Marking example for I/O modules according to NEC 500

Table 3: Description of marking example for I/O modules according to NEC 500

Printing on Text	Description
CL 1	Explosion protection group (condition of use category)
DIV 2	Area of application (zone)
Grp. ABCD	Explosion group (gas group)
Optemp code T4	Temperature class

6.2 Installation Regulations

In the **Federal Republic of Germany**, various national regulations for the installation in explosive areas must be taken into consideration. The basis for this forms the working reliability regulation, which is the national conversion of the European guideline 99/92/E6. They are complemented by the installation regulation EN 60079-14. The following are excerpts from additional VDE regulations:

Table 4: VDE Installation Regulations in Germany

DIN VDE 0100	Installation in power plants with rated voltages up to 1000 V
DIN VDE 0101	Installation in power plants with rated voltages above 1 kV
DIN VDE 0800	Installation and operation in telecommunication plants including information processing equipment
DIN VDE 0185	lightning protection systems

The **USA** and **Canada** have their own regulations. The following are excerpts from these regulations:

Table 5: Installation Regulations in USA and Canada

NFPA 70	National Electrical Code Art. 500 Hazardous Locations
ANSI/ISA-RP 12.6-1987	Recommended Practice
C22.1	Canadian Electrical Code

NOTICE

Notice the following points

When using the **WAGO-I/O SYSTEM 750** (electrical operation) with Ex approval, the following points are mandatory:

6.2.1 Special Conditions for Safe Operation of the ATEX and IEC Ex (acc. DEMKO 08 ATEX 142851X and IECEx PTB 07.0064)

The fieldbus-independent I/O modules of the WAGO-I/O-SYSTEM 750-.../...-... must be installed in an environment with degree of pollution 2 or better. In the final application, the I/O modules must be mounted in an enclosure with IP 54 degree of protection at a minimum with the following exceptions:

- I/O modules 750-440, 750-609 and 750-611 must be installed in an IP 64 minimum enclosure.
- I/O module 750-540 must be installed in an IP 64 minimum enclosure for 230 V AC applications.
- I/O module 750-440 may be used up to max. 120 V AC.

When used in the presence of combustible dust, all devices and the enclosure shall be fully tested and assessed in compliance with the requirements of IEC 61241-0:2004 and IEC 61241-1:2004.

When used in mining applications the equipment shall be installed in a suitable enclosure according to EN 60079-0:2006 and EN 60079-1:2007.

I/O modules fieldbus plugs or fuses may only be installed, added, removed or replaced when the system and field supply is switched off or the area exhibits no explosive atmosphere.

DIP switches, coding switches and potentiometers that are connected to the I/O module may only be operated if an explosive atmosphere can be ruled out.

I/O module 750-642 may only be used in conjunction with antenna 758-910 with a max. cable length of 2.5 m.

To exceed the rated voltage no more than 40%, the supply connections must have transient protection.

The permissible ambient temperature range is 0 °C to +55 °C.

6.2.2 Special conditions for safe use (ATEX Certificate TÜV 07 ATEX 554086 X)

1. For use as Gc- or Dc-apparatus (in zone 2 or 22) the field bus independent I/O modules WAGO-I/O-SYSTEM 750-*** shall be erected in an enclosure that fulfils the requirements of the applicable standards (see the marking) EN 60079-0, EN 60079-11, EN 60079-15, EN 61241-0 and EN 61241-1. For use as group I, electrical apparatus M2, the apparatus shall be erected in an enclosure that ensures a sufficient protection according to EN 60079-0 and EN 60079-1 and the degree of protection IP64. The compliance of these requirements and the correct installation into an enclosure or a control cabinet of the devices shall be certified by an ExNB.
2. If the interface circuits are operated without the field bus coupler station type 750-3../...-... (DEMKO 08 ATEX 142851 X), measures must be taken outside of the device so that the rating voltage is not being exceeded of more than 40% because of transient disturbances.
3. DIP-switches, binary-switches and potentiometers, connected to the module may only be actuated when explosive atmosphere can be excluded.
4. The connecting and disconnecting of the non-intrinsically safe circuits is only permitted during installation, for maintenance or for repair purposes. The temporal coincidence of explosion hazardous atmosphere and installation, maintenance resp. repair purposes shall be excluded. This is although and in particular valid for the interfaces “CF-Card”, “USB”, “Fieldbus connection“, “Configuration and programming interface“, “antenna socket“, “D-Sub“ and the “Ethernet interface“. These interfaces are not energy limited or intrinsically safe circuits. An operating of those circuits is in the behalf of the operator.
5. For the types 750-606, 750-625/000-001, 750-487/003-000, 750-484 and 750-633 the following shall be considered: The interface circuits shall be limited to overvoltage category I/II/III (non mains/mains circuits) as defined in EN 60664-1.
6. For the type 750-601 the following shall be considered: Do not remove or replace the fuse when the apparatus is energized.
7. The ambient temperature range is: $0^{\circ}\text{C} \leq T_a \leq +55^{\circ}\text{C}$ (for extended details please note certificate).

8. The following warnings shall be placed nearby the unit:

 **WARNING**

Do not remove or replace fuse when energized!

If the module is energized do not remove or replace the fuse.

 **WARNING**

Do not separate when energized!

Do not separate the module when energized!

 **WARNING**

Separate only in a non-hazardous area!

Separate the module only in a non-hazardous area!

6.2.3 Special conditions for safe use (IEC-Ex Certificate TUN 09.0001 X)

1. For use as Dc- or Gc-apparatus (in zone 2 or 22) the fieldbus independent I/O modules WAGO-I/O-SYSTEM 750-*** shall be erected in an enclosure that fulfils the requirements of the applicable standards (see the marking) IEC 60079-0, IEC 60079-11, IEC 60079-15, IEC 61241-0 and IEC 61241-1. For use as group I, electrical apparatus M2, the apparatus shall be erected in an enclosure that ensures a sufficient protection according to IEC 60079-0 and IEC 60079-1 and the degree of protection IP64. The compliance of these requirements and the correct installation into an enclosure or a control cabinet of the devices shall be certified by an ExCB.
2. Measures have to be taken outside of the device that the rating voltage is not being exceeded of more than 40% because of transient disturbances.
3. DIP-switches, binary-switches and potentiometers, connected to the module may only be actuated when explosive atmosphere can be excluded.
4. The connecting and disconnecting of the non-intrinsically safe circuits is only permitted during installation, for maintenance or for repair purposes. The temporal coincidence of explosion hazardous atmosphere and installation, maintenance resp. repair purposes shall be excluded. This is although and in particular valid for the interfaces “CF-Card”, “USB”, “Fieldbus connection“, “Configuration and programming interface“, “antenna socket“, “D-Sub“ and the “Ethernet interface“. These interfaces are not energy limited or intrinsically safe circuits. An operating of those circuits is in the behalf of the operator.
5. For the types 750-606, 750-625/000-001, 750-487/003-000, 750-484 and 750-633 the following shall be considered: The interface circuits shall be limited to overvoltage category I/II/III (non mains/mains circuits) as defined in IEC 60664-1.
6. For the type 750-601 the following shall be considered: Do not remove or replace the fuse when the apparatus is energized.
7. The ambient temperature range is: $0^{\circ}\text{C} \leq T_a \leq +55^{\circ}\text{C}$ (For extensions please see the certificate).

8. The following warnings shall be placed nearby the unit:

 **WARNING**

Do not remove or replace fuse when energized!

If the module is energized do not remove or replace the fuse.

 **WARNING**

Do not separate when energized!

Do not separate the module when energized!

 **WARNING**

Separate only in a non-hazardous area!

Separate the module only in a non-hazardous area!

6.2.4 ANSI/ISA 12.12.01

This equipment is suitable for use in Class I, Division 2, Groups A, B, C, D or non-hazardous locations only.

This equipment is to be fitted within tool-secured enclosures only.

 **WARNING**

Explosion hazard!

Explosion hazard - substitution of components may impair suitability for Class I, Div. 2.

 **WARNING**

Disconnect device when power is off and only in a non-hazardous area!

Do not disconnect equipment unless power has been switched off or the area is known to be non-hazardous near each operator accessible connector and fuse holder." When a fuse is provided, the following information shall be provided: "A switch suitable for the location where the equipment is installed shall be provided to remove the power from the fuse."

For devices with Ethernet connectors:

"Only for use in LAN, not for connection to telecommunication circuits".

 **WARNING**

Use only with antenna module 758-910!

Use Module 750-642 only with antenna module 758-910.

For Couplers/Controllers and Economy bus modules only: "The configuration Interface Service connector is for temporary connection only. Do not connect or disconnect unless the area is known to be nonhazardous. Connection or disconnection in an explosive atmosphere could result in an explosion.

 **WARNING**

Devices containing fuses must not be fitted into circuits subject to over loads!

Devices containing fuses must not be fitted into circuits subject to over loads, e.g. motor circuits!

 **WARNING**

Do not connect or disconnect SD-Card unless the area known to be free of ignitable concentrations of flammable gases or vapors!

Do not connect or disconnect SD-Card while circuit is live unless the area is known to be free of ignitable concentrations of flammable gases or vapors.

Information



Additional Information

Proof of certification is available on request. Also take note of the information given on the module technical information sheet. The Instruction Manual, containing these special conditions for safe use, must be readily available to the user.



WAGO Kontakttechnik GmbH & Co. KG
Postfach 2880 • D-32385 Minden
Hansastraße 27 • D-32423 Minden
Phone: 05 71/8 87 – 0
Fax: 05 71/8 87 – 1 69
E-Mail: info@wago.com

Internet: <http://www.wago.com>
